

## **Maintenance Guide**

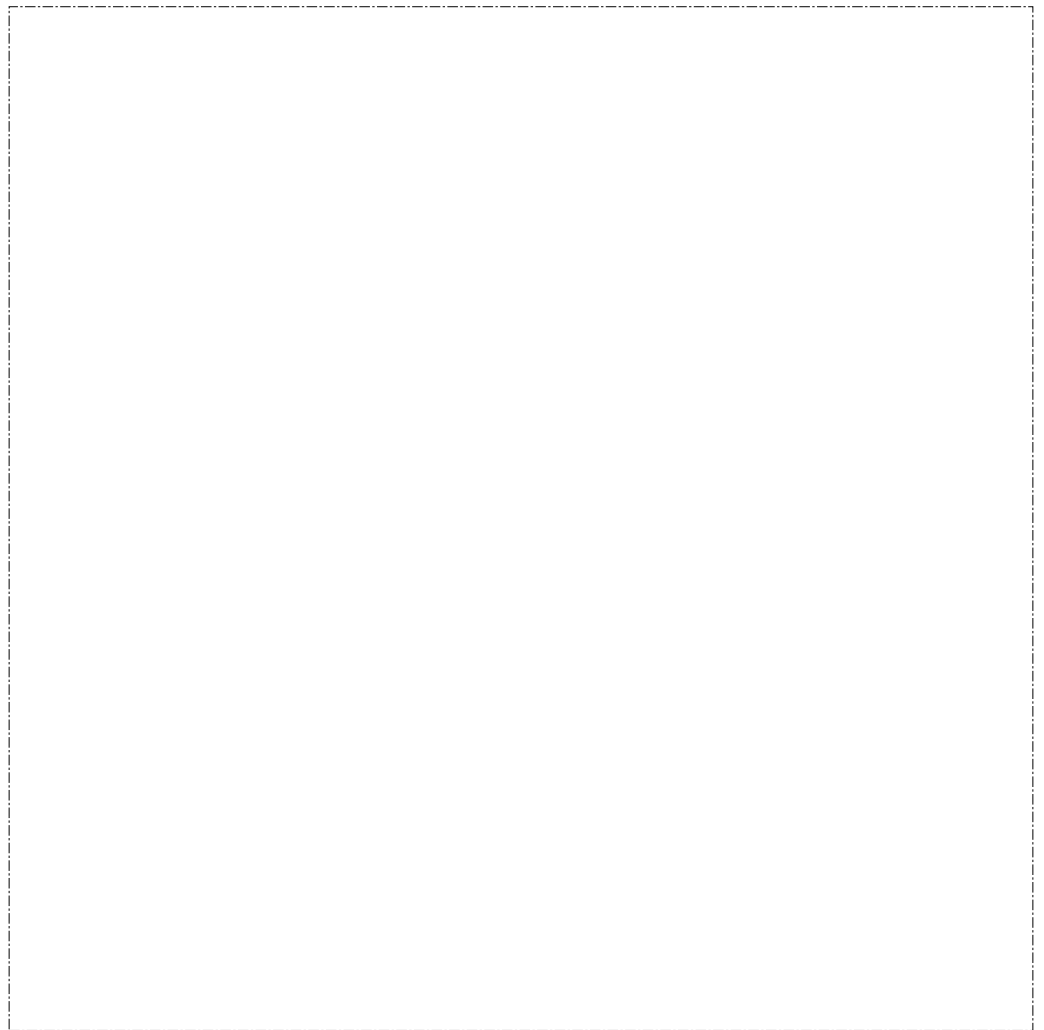





2216 Nways Multiaccess Connector

SY27-0350-00

## **Maintenance Guide**

**Note**

Before using this information and the product it supports, be sure to read the general information under Appendix A, "Notices" on page A-1.

**First Edition (March 1997)**

This edition applies to the IBM 2216 Nways Multiaccess Connector Model 400.

Order publications through your IBM representative or the IBM branch office serving your locality. Publications are not stocked at the address given below.

A form for readers' comments appears at the back of this publication. If the form has been removed, address your comments to:

Department CGF  
Design & Information Development  
IBM Corporation  
PO Box 12195  
RESEARCH TRIANGLE PARK NC 27709-9990  
USA

When you send information to IBM, you grant IBM a non-exclusive right to use or distribute the information in any way it believes appropriate without incurring any obligation to you.

© **Copyright International Business Machines Corporation 1997. All rights reserved.**

Note to U.S. Government Users — Documentation related to restricted rights — Use, duplication or disclosure is subject to restrictions set forth in GSA ADP Schedule Contract with IBM Corp.

---

# Contents

<b>About This Manual</b> . . . . .	v
Who Should Read This Manual . . . . .	v
How this Manual is Organized . . . . .	v
Library Overview . . . . .	vii
<b>Chapter 1. LED Indicators</b> . . . . .	1-1
2216 Power Supply . . . . .	1-1
System Card LEDs . . . . .	1-2
Adapter LEDs . . . . .	1-2
<b>Chapter 2. 2216 Problem Determination</b> . . . . .	2-1
MAP 0600: 2216 Basic Verification . . . . .	2-1
Service Kit—Feature Code 2505 . . . . .	2-6
<b>Chapter 3. 2216 FRU Exchange</b> . . . . .	3-1
Exchanging a Power Supply . . . . .	3-2
Exchanging the System Card . . . . .	3-3
Exchanging the Hard Drive on the System Card . . . . .	3-5
Installing Operational Software on the New Hard Drive . . . . .	3-7
Exchanging the Fan Tray . . . . .	3-8
Exchanging an Adapter . . . . .	3-9
Exchanging the Backplane . . . . .	3-12
<b>Chapter 4. Using IBM 2216 Firmware</b> . . . . .	4-1
Attended Mode . . . . .	4-1
Unattended Mode . . . . .	4-1
Starting 2216 Firmware . . . . .	4-2
Obtaining Help . . . . .	4-2
Managing the Configuration . . . . .	4-3
Selecting the Boot Sequence . . . . .	4-4
Selecting a Device To Test . . . . .	4-5
Using the Utilities . . . . .	4-7
Setting the Power-On Password . . . . .	4-8
Setting the Supervisory Password . . . . .	4-9
Enabling Unattended Start Mode . . . . .	4-10
Disabling Unattended Start Mode . . . . .	4-11
Removing the Supervisory Password . . . . .	4-12
Updating System Firmware . . . . .	4-13
Displaying the Error Log . . . . .	4-14
Viewing or Setting Vital Product Data . . . . .	4-15
Copying Remote Files . . . . .	4-17
Setting Up Remote Initial Program Load . . . . .	4-18
Xmodem Software Selection in Change Management . . . . .	4-19
<b>Chapter 5. Using Operational Diagnostics</b> . . . . .	5-1
<b>Appendix A. Notices</b> . . . . .	A-1
Electronic Emission Notices . . . . .	A-1
European Community (EC) Mark of Conformity Statement . . . . .	A-4
Japanese Voluntary Control Council for Interference (VCCI) Statement . . . . .	A-4

Korean Communications Statement . . . . .	A-5
Trademarks . . . . .	A-5
<b>Appendix B. Firmware Error Codes . . . . .</b>	<b>B-1</b>
<b>Appendix C. Common Tasks . . . . .</b>	<b>C-1</b>
LED States / Adapter Status . . . . .	C-1
The Firmware Interface . . . . .	C-1
Command Line Interface . . . . .	C-1
Displaying List of Active Interfaces . . . . .	C-1
Displaying the Operational State of the Interfaces . . . . .	C-2
Verifying Connectivity . . . . .	C-2
Viewing Vital Software Data . . . . .	C-2
Viewing Vital Hardware Data . . . . .	C-3
Adding an Adapter at Initial Configuration . . . . .	C-3
Adding an Adapter after Initial Configuration . . . . .	C-4
Running Quick Configuration . . . . .	C-4
Disabling an Adapter Port . . . . .	C-5
Enabling an Adapter Port . . . . .	C-5
Disabling an Adapter Port to Suspend Traffic . . . . .	C-6
Enabling an Adapter Port to Resume Traffic . . . . .	C-6
Removing and Deleting an Adapter . . . . .	C-7
Running Diagnostics . . . . .	C-7
Up-to-Date IBM 2216 Information . . . . .	C-7
Disabling Interfaces that have WAN Reroute Enabled . . . . .	C-8
Enable WAN Reroute after you have Disabled it . . . . .	C-8
<b>Appendix D. Factory Plugging Defaults . . . . .</b>	<b>D-1</b>
Assumptions . . . . .	D-1
Plugging Sequences . . . . .	D-1
<b>Appendix E. Parts Listing . . . . .</b>	<b>E-1</b>
Assembly 1: Final Assembly, Routing Subsystem Console Commands - Model 400 . . . . .	E-2
2216-400 Feature Codes . . . . .	E-4
2216 Feature Card Cables . . . . .	E-5
<b>List of Abbreviations . . . . .</b>	<b>X-1</b>
<b>Glossary . . . . .</b>	<b>X-3</b>
<b>Index . . . . .</b>	<b>X-7</b>

---

## About This Manual

This manual provides the service representative with the information needed to:

- Analyze a problem or symptoms reported by the user
- Restore normal operation to the 2216
- Exchange any of the FRUs of the 2216
- Run firmware and operational diagnostics.

---

## Who Should Read This Manual

This manual is for the use of the person providing level 1 remote support of the IBM 2216. Also, IBM service representatives will refer to this manual when servicing the 2216 on site. The person using this manual should be:

- Trained to service the 2216.
- Familiar with the configuration and operation of the 2216.

---

## How this Manual is Organized

This manual contains the following chapters and appendixes:

- Chapter 1, "LED Indicators" gives an overview of the 2216.
- Chapter 2, "2216 Problem Determination" gives problem determination procedures for the 2216.
- Chapter 3, "2216 FRU Exchange" explains the procedures for exchanging the field-replaceable units (FRUs) on the 2216.
- Chapter 4, "Using IBM 2216 Firmware" describes how to run the 2216 firmware.
- Chapter 5, "Using Operational Diagnostics" gives procedures for running the operational diagnostics.
- Appendix A, "Notices" provides proprietary notices, electronic emission notices, and trademark information.
- Appendix B, "Firmware Error Codes" lists error codes provided by the firmware.
- Appendix C, "Common Tasks" contains a series of questions and answers regarding the installation, configuration, and operation of the IBM 2216 to serve as a guide for performing various common tasks.
- Appendix D, "Factory Plugging Defaults" describes the sequence in which adapters are installed at the factory.

Planning and Installation

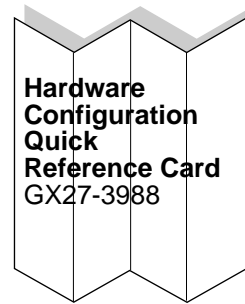
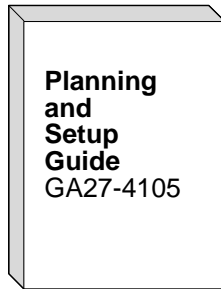

Configuration

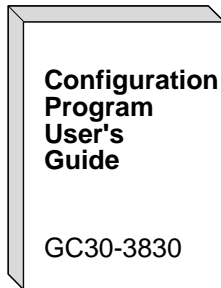

Diagnostics/Maintenance

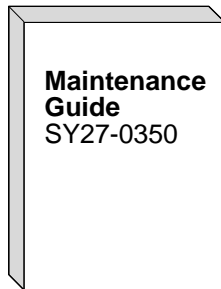

Operations and Network Administration

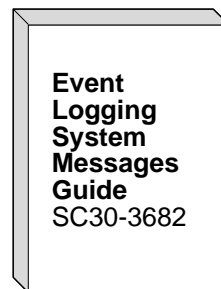
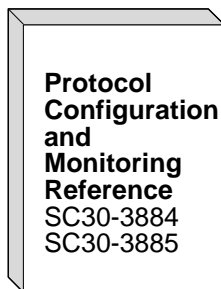
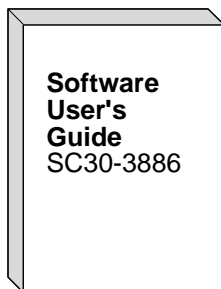



---

## Library Overview

The following list shows the books in the IBM 2216 library, arranged according to tasks.

**Information updates and corrections:** To keep you informed of engineering changes, clarifications, and fixes that were implemented after the books were printed, refer to the IBM 2216 home pages at:

<http://www.networking.ibm.com/216/216prod.html>  
and  
<http://www.networking.ibm.com/216/216lib.html>

### Planning

GA27-4105 *2216 Nways Multiaccess Connector Planning and Setup Guide*

This book is shipped with the IBM 2216. It explains how to prepare for installation and perform an initial configuration.

### Installation

GA27-4106 *2216 Nways Multiaccess Connector Hardware Installation Guide*

This booklet is shipped with the IBM 2216. It explains how to install the IBM 2216 and verify its installation.

GX27-3988 *2216 Nways Multiaccess Connector Hardware Configuration Quick Reference*

This reference card is used for entering and saving hardware configuration information used to determine the correct state of an IBM 2216.

### Diagnostics and Maintenance

SY27-0350 *2216 Nways Multiaccess Connector Maintenance Guide.*

This book is shipped with the IBM 2216 It provides instructions for diagnosing problems with and repairing the IBM 2216.

### Operations and Network Management

The following list shows the books that support the Nways Multiprotocol Access Services program.

SC30-3886 *Nways Multiprotocol Access Services Software User's Guide*

This book explains how to:

- Configure, monitor, and use the Nways Multiprotocol Access Services software.
- Use the Nways Multiprotocol Access Services command-line router user interface to configure and monitor the network interfaces and link-layer protocols shipped with the IBM 2216.

SC30-3884 *Nways Multiprotocol Access Services Protocol Configuration and Monitoring Reference, Volume 1*

SC30-3885 *Nways Multiprotocol Access Services Protocol Configuration and Monitoring Reference, Volume 2*

These books describe how to access and use the Nways

Multiprotocol Access Services command-line user interface to configure and monitor the routing protocol software shipped with the product.

They include information about each of the protocols that the devices support.

SC30-3682 *Nways Event Logging System Messages Guide*

This book contains a listing of the error codes that can occur, along with descriptions and recommended actions to correct the errors.

**Configuration**

GC30-3830 *Configuration Program User's Guide*

This book discusses how to use the Nways Multiprotocol Access Services Configuration Program.

**Safety**

SD21-0030 *Caution: Safety Information—Read This First*

This book, shipped with the IBM 2216, provides translations of caution and danger notices applicable to the installation and maintenance of a IBM 2216.

**Marketing**

URL: <http://www.networking.ibm.com/216/216prod.html>

This IBM Web page provides product information through the World Wide Web.

---

## Chapter 1. LED Indicators

The IBM 2216 has a number of light-emitting diodes (LEDs) that indicate how the unit is functioning. This chapter explains how to determine the status of the IBM 2216 by observing these indicators.

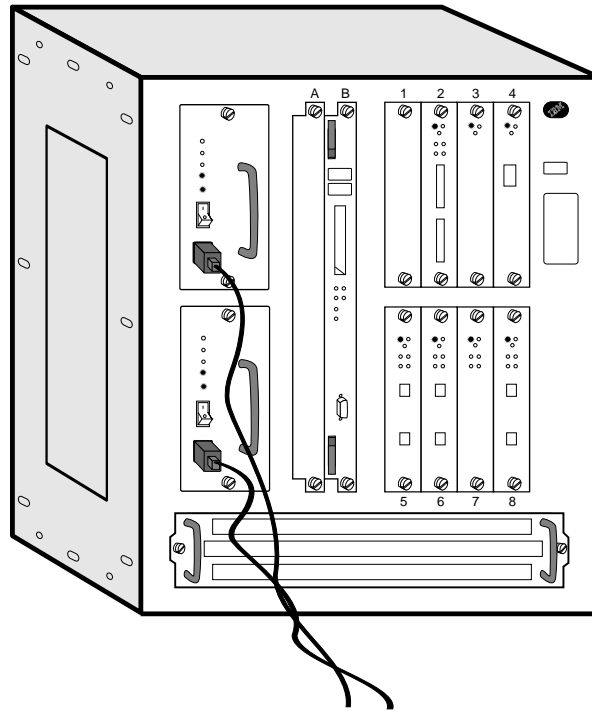

---

### 2216 Power Supply

The power supply panel contains:

- The power switch, which is used to power ON or OFF the 2216
- The Overcurrent Reset switch, which resets all current-limit circuits for the +12 V and -48 V outputs at the same time
- The following LEDs:

**AC Indicator**

A green LED indicating the presence of ac source voltage

**DC Indicator**

A green LED indicating the presence of +5 V, +12 V, and -48 V dc output voltages

**Overcurrent Indicator**

A yellow LED indicating that the +12 V output (fan assembly) or one or more of the -48 V outputs (adapter slots 1–8) have been switched off by their current-limit circuits. For example, the overcurrent indicator will light if an adapter has failed in one of the slots, causing power to be switched off to that slot.

---

## System Card LEDs

After power-on-reset (POR), the green and yellow LED's will remain on until successful completion of the power on tests (which will be under 2 minutes). The green LED will begin blinking, which indicates that the code is being loaded into memory. The green LED will be switched on to indicate that the system code is operational.

The following LED conditions can exist after a reset:

<b>Green</b>	ON - card is operational. BLINKING - loading from hard file
<b>Yellow</b>	ON - card has a fault.
<b>PCMCIA Port 1 or Port 2 (yellow)</b>	ON - device is plugged in and fails a test or is inaccessible. (The yellow LED will be ON if no device is plugged in.) OFF - device passes test.
<b>Hard Drive (yellow)</b>	ON - there is a failure of the hard drive.

---

## Adapter LEDs

<b>Green</b>	ON - the card is operational.
<b>Yellow</b>	ON - a card fault has been detected.
<b>Wrong slot (yellow)</b>	ON - card is in a wrong slot.
<b>Green Port LED</b>	ON - the port is enabled and configured. OFF - the port is disabled or not configured.
<b>Yellow Port LED</b>	ON - there is a hardware fault. BLINKING - there is a port I/O, cable, or network failure. (Use external wrap block/diagnostic to isolate.) OFF - no problem has been detected.
<b>Note:</b> The port LEDs of the multiport WAN adapters (FC 2282, FC 2291, and FC 2292) have slightly different meanings:	
<b>Green Port LED</b>	ON - one or more of the ports is enabled and configured. OFF - none of the ports is enabled and configured.
<b>Yellow Port LED</b>	ON - one or more of the ports has a hardware fault. BLINKING - there is a port I/O, cable, or network failure. (Use external wrap block/diagnostic to isolate.) OFF - no problem has been detected.

---

## Chapter 2. 2216 Problem Determination

**Note:** The 2216 service representative will need to have the diagnostics run remotely by the operator at a station connected via the modem. Alternatively, the servicer can run the diagnostics on site through an ASCII terminal connected directly to the 2216.

### MAP 0600: 2216 Basic Verification

001

- On the 2216 power supply, switch the power ON.
- Within 2 minutes, check the status of the LEDs on the front of the 2216.
- The LEDs on the 2216 should have the following status:

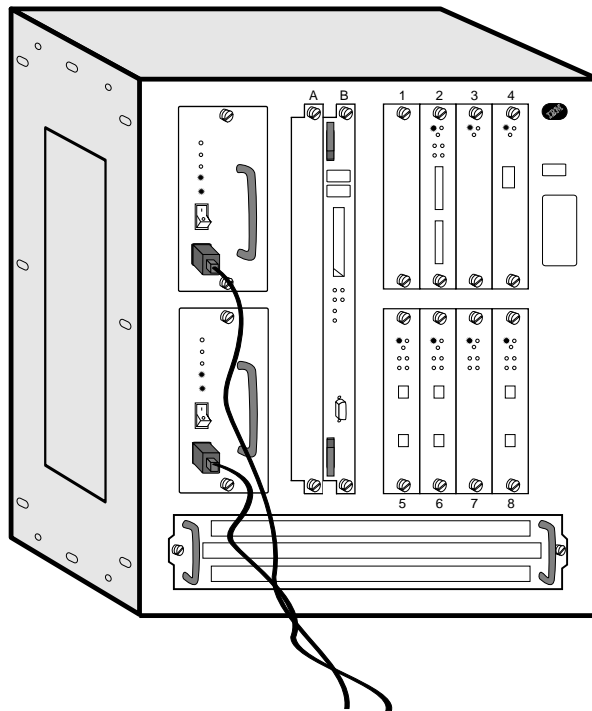

Table 2-1 on page 2-2 shows the desired status of the LEDs. Table 2-2 on page 2-2 shows messages that may appear at the operator console attached to the IBM 2216 that may indicate a problem.

## MAP 0600 (continued)

<i>Table 2-1. Machine LEDs</i>		
LED	Status	Comments
AC indicator LED on power supply	ON	AC power is present and within the correct tolerances.
DC indicator LED on power supply	ON	DC output voltage is present.
Yellow LED on power supply	OFF	There is no overcurrent problem with the adapters or fan tray.
Green LED on system card	ON	The card is operational.
Yellow LED on system card	OFF	The card is OK.
PCMCIA Port 1 (yellow) on system card	OFF	The device has passed test.
PCMCIA Port 2 (yellow) on system card	OFF	The device has passed test.
All adapter green LEDs	ON	The adapter is operational.
All adapter yellow LEDs	OFF	ON indicates a hardware fault.
Wrong slot LED	OFF	The adapter is plugged into the correct slot.
All I/O port green LEDs	ON	The port is enabled and configured.
All I/O port yellow LEDs	OFF	<ul style="list-style-type: none"> <li>• ON indicates that a fault has been detected.</li> <li>• BLINKING indicates a port or network failure.</li> </ul>

<i>Table 2-2. Network Management Console Messages</i>	
Message	Comments
Fan motor speed	Replace fan assembly
2216 is overheating	Check for: <ul style="list-style-type: none"> <li>• Room air conditioning</li> <li>• Obstruction of airflow</li> <li>• Fan motor problem</li> </ul>
Memory error with DIMM slot y	Replace the system card. See "Exchanging the System Card" on page 3-3.

### Are all LEDs OK?

Yes No

002

Go to Step 004

003

The 2216 should be functioning.

---

004

- In Table 2-3 on page 2-3, select the symptom that fits your situation.

<i>Table 2-3. LED and symptoms</i>	
<b>LED Status</b>	<b>Action</b>
<b>AC indicator</b> LED on a power supply is OFF.	Step 005 on page 2-3
<b>DC indicator</b> LED on a power supply is OFF and the ac indicator is ON.	Step 008 on page 2-3
<b>Overcurrent Indicator</b> LED on power supply is ON.	Step 011 on page 2-4
<b>Adapter yellow fault indicator LED</b> is ON (adapter is failing).	Step 018 on page 2-4
Adapter <b>Yellow</b> Wrong Slot LED is ON.	Step 021 on page 2-4
I/O port <b>Yellow</b> indicator is ON or BLINKING.	Step 022 on page 2-5
Yellow indicator on system card is ON	Step 025 on page 2-5

**005**

You are at this step because the ac indicator on a power supply is OFF. Perform the following tests:

1. On the suspected power supply, check that:
  - The power cable is correctly connected to the ac power outlet and to the front of the power supply.
  - The power supply is correctly seated in the unit.
2. With a multimeter, check that there is power at the power outlet.
3. With the power cable connected to the power outlet, use a multimeter to verify that the power cable is good.

If you detect no problems with any of the above, replace the power supply. See “Exchanging a Power Supply” on page 3-2.

**Is the ac indicator LED now ON?**

**Yes No**

**006**

Call your support center for assistance.

**007**

Restart the verification procedure. Go to Step 001 on page 2-1.

**008**

**The dc indicator on a power supply is OFF. Replace the power supply. (See “Exchanging a Power Supply” on page 3-2.) Is the problem corrected?**

**Yes No**

**009**

Contact your support center for assistance.

**010**

(Step **010** continues)

## MAP 0600 (continued)

**010** (continued)

Restart the verification procedure. Go to Step 001 on page 2-1.

---

**011**

The Overcurrent LED on a power supply is ON. Are all adapter yellow fault LEDs OFF?

Yes No

**012**

Remove the adapter with a yellow fault LED ON, then press Reset on the power supply. Is the Overcurrent LED now OFF?

Yes No

**013**

Replace the power supply. Restart the verification procedure. Go to Step 001 on page 2-1.

**014**

Replace the adapter. (See “Exchanging an Adapter” on page 3-9.) Restart the verification procedure. Go to Step 001 on page 2-1.

---

**015**

The problem may be with the fan tray. Remove it (see “Exchanging the Fan Tray” on page 3-8) and press Reset. Does this correct the problem?

Yes No

**016**

Contact your support center.

**017**

Replace the fan tray and restart the verification procedure. Go to Step 001 on page 2-1.

---

**018**

A yellow fault indicator LED on an adapter is ON. Replace the adapter. (See “Exchanging an Adapter” on page 3-9.) Does this correct the problem?

Yes No

**019**

Contact your support center.

**020**

Restart the verification procedure. Go to Step 001 on page 2-1.

---

**021**

The **yellow** Wrong Slot LED indicator on an adapter is ON.

- If adapter LIC 280 or LIC 281 is in slot 3, then slot 4 must be empty.
- (Step **021** continues)



**021** (continued)

- If adapter LIC 280 or LIC 281 is in slot 4, then slot 3 must be empty.
- If adapter LIC 280 or LIC 281 is in slot 7, then slot 8 must be empty.
- If adapter LIC 280 or LIC 281 is in slot 8, then slot 7 must be empty.

The Wrong Slot LED indicates that one of the above restrictions is not being observed. Relocate the adapter or adapters in slots 3, 4, 7, or 8 accordingly. Restart the verification procedure. Go to Step 001 on page 2-1.

---

**022**

**A yellow LED indicator for an I/O port is ON or BLINKING. Is the yellow LED indicator BLINKING?**

**Yes No**

**023**

**I/O port LED ON** - The adapter is defective. Replace it. (See “Exchanging an Adapter” on page 3-9.) Restart the verification procedure. Go to Step 001 on page 2-1.

**024**

**I/O port LED BLINKING -**

There is a problem with the adapter, the cable, or the network. Run an external wrap test on the I/O port. See “Selecting a Device To Test” on page 4-5. You must install an external wrap block (plug) prior to the test. See “Adapter Wrap Plugs” on page 2-6 for the correct wrap plug. If the wrap test is successful, suspect the cable or the network. Correct any problem that you find. Restart the verification procedure. Go to Step 001 on page 2-1.

---

**025**

**The yellow LED on the system card is ON. Is the Hard Drive LED ON?**

**Yes No**

**026**

The system card is defective. Replace it. See “Exchanging the System Card” on page 3-3. Restart the verification procedure. Go to Step 001 on page 2-1.

**027**

There is a hard drive failure. Replace the hard drive. See “Exchanging the Hard Drive on the System Card” on page 3-5. Restart the verification procedure. Go to Step 001 on page 2-1.

---

## Service Kit—Feature Code 2505

The optional service kit provides wrap plugs for all IBM 2216 interfaces except for the ARCs.

### Adapter Wrap Plugs

Table 2-4. IBM 2216 Adapter Wrap Plugs

Adapter	FRU P/N	Feature Code	Description	Wrap Plugs
LIC 280	85H5543	FC 2280	2-Port Token-Ring	UTP 04H8210
LIC 281	85H5542	FC 2281	2-Port Ethernet	UTP 04H8210 BNC 02G7433
LIC 282	85H4872	FC 2282	8-Port EIA 232	CRD 68F7208 CBL 33F8985
LIC 283	85H4882	FC 2283	1-Port ISDN Pri (T1)	57G8097
LIC 284	85H4894	FC 2284	1-Port 155 Mbps (MMF ATM)	16G5609
LIC 290	85H4874	FC 2290	6-Port V.35/V.36	CRD 72F0168 V.35 BRICK 72F0167 V.36 CBL 73H2508
LIC 291	85H4876	FC 2291	8-Port X.21	CRD 06H3357 CBL 52G3378
LIC 292	85H4884	FC 2292	1-Port ISDN Pri (E1)	57G8097
LIC 293	85H6834	FC 2293	1-Port 155 Mbps (SMF ATM)	16G5609

## LIC 282, LIC 290, and LIC 291 External Wraps

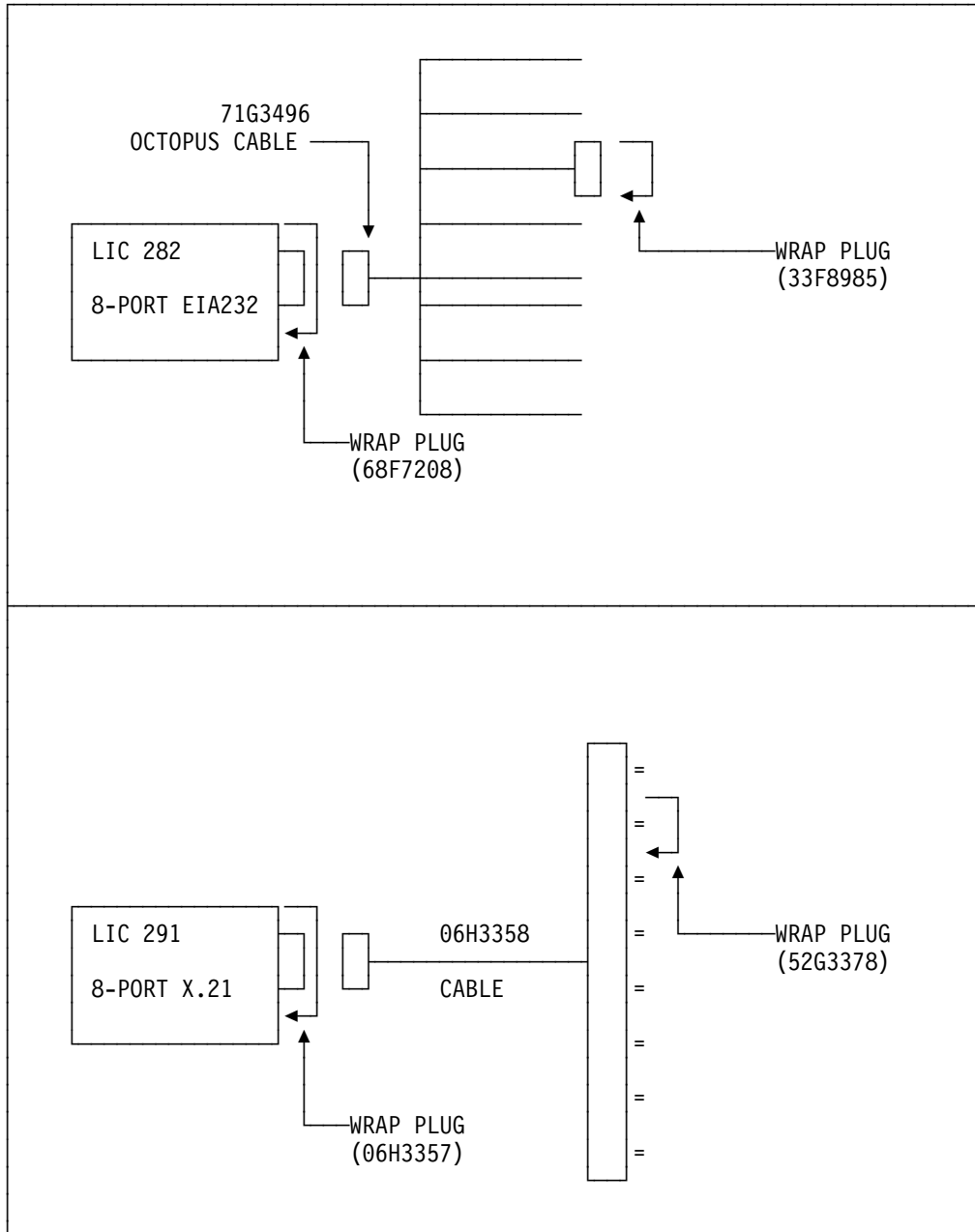

Figure 2-1. LIC 282 and LIC 291 Wrap Support

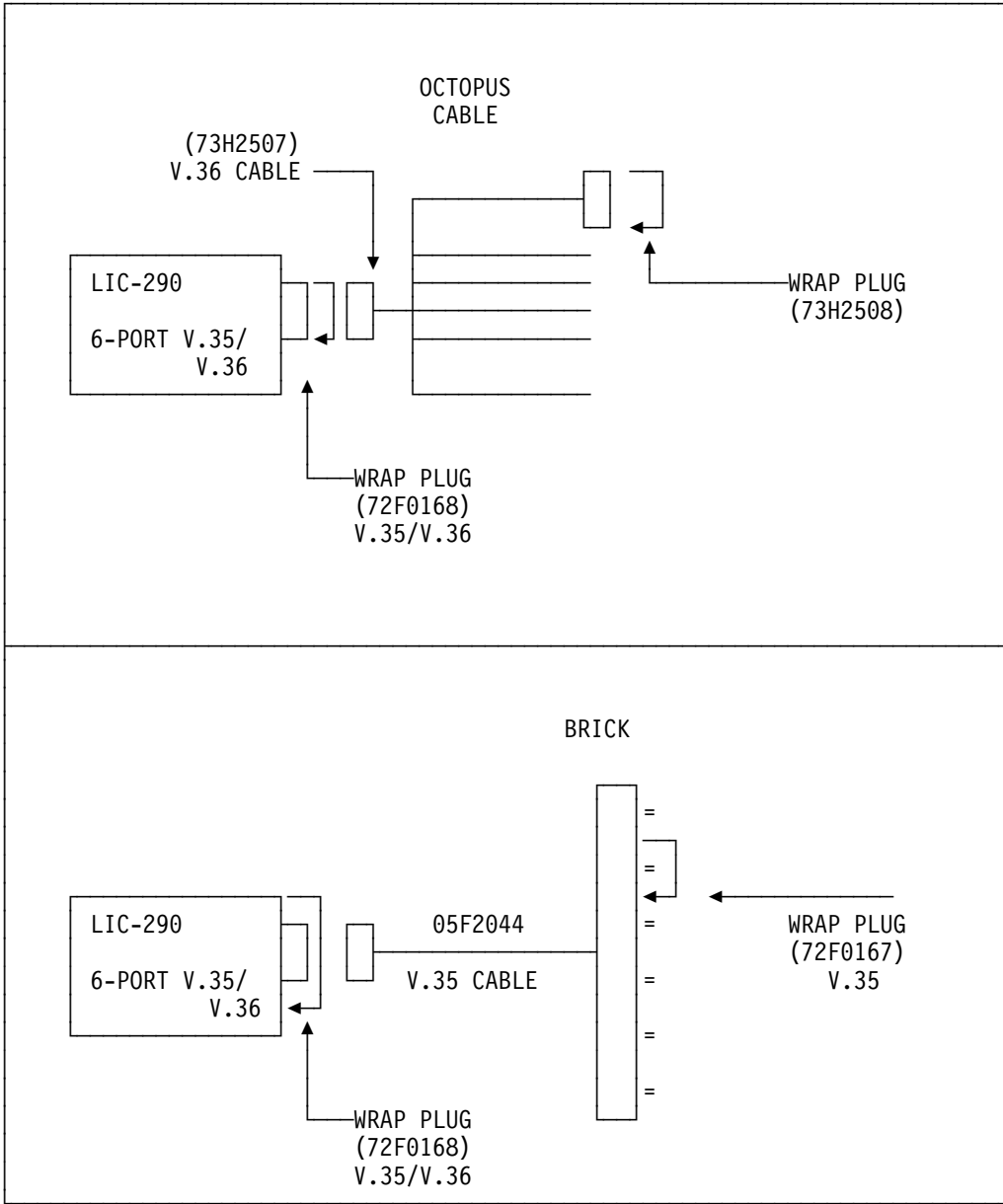

Figure 2-2. LIC 290 Wrap Support

---

## Chapter 3. 2216 FRU Exchange

### Important

The system card and a single power supply are **not** hot pluggable. This means that you must switch off power to the adapter when replacing either of them. Other FRUs are hot pluggable and can be exchanged without powering OFF the 2216, although the adapter or other FRU must be reset before new configurations can take effect. Follow carefully the procedure described.

Before removing an adapter, be sure that the corresponding resource has been **disabled** by the operator at the operator console.

Each time you change a FRU, carefully record its location and check that the attached cables are correctly labeled and reconnected.

In Table 3-1, find the FRU you want to exchange and go to the procedure indicated.

FRU Name	Go to
Power supply	"Exchanging a Power Supply" on page 3-2
System card	"Exchanging the System Card" on page 3-3
Hard drive	"Exchanging the Hard Drive on the System Card" on page 3-5
Fan tray	"Exchanging the Fan Tray" on page 3-8
Adapter type xxx	"Exchanging an Adapter" on page 3-9
Backplane	"Exchanging the Backplane" on page 3-12

---

## Exchanging a Power Supply

**Attention:** A power supply is hot pluggable if an optional load-sharing power supply is also installed.

- 1** Switch off the power supply.
- 2** Unplug the power cord.
- 3** Remove the power supply by loosening the screws at the top and bottom and pulling the handle.

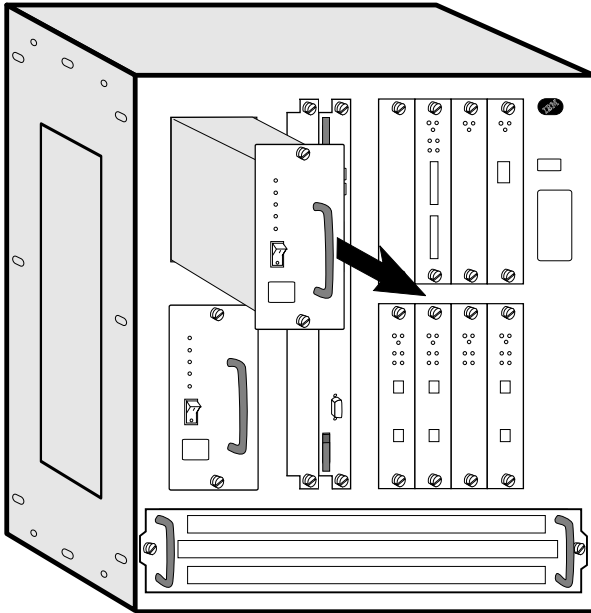

- 4** Install the new power supply. The power supply will slide into place on metal rails in the unit.
- 5** Attach the power cord.
- 6** Switch on the power.
- 7** Verify the LEDs. See “Adapter LEDs” on page 1-2.
- 8** Notify the network administrator that you are finished repairing the 2216.

---

## Exchanging the System Card

### Attention:

1. The system card is **not** hot pluggable.
2. Remove the hard drive from the new system card. The hard drive that comes with the new system card is **blank**.

- 1** Switch off each power supply.
- 2** Label the cables on the system card. Unplug the cables and the PCMCIA modem (or other PCMCIA cards).
- 3** Loosen thumbscrews on the system card.
- 4** Remove the defective system card.

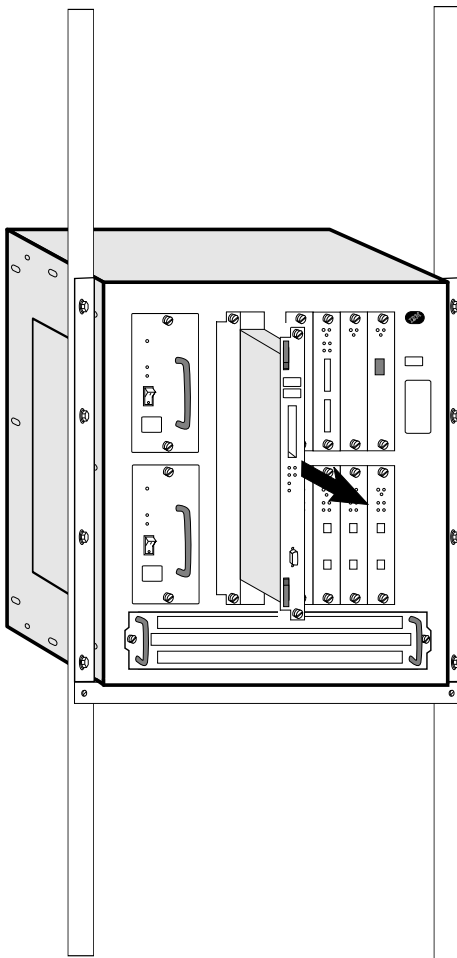

- 5** Remove the hard drive from the defective system card and install it on a new system card (see “Exchanging the Hard Drive on the System Card” on page 3-5). Return the hard drive that came with the new system card with the defective system card. The hard drive that comes with the new system card is blank.

- 6** Install the new system card. Make sure the card is aligned with the plastic grooves and then slide it in until it is flush with the box.  
  
Hold the locking latches so that they are perpendicular to the face of the system card. With the card in full contact with the rear of the IBM 2216, press the locking latches into the system card.
- 7** Tighten the thumbscrews on the face of the adapter card clockwise.
- 8** Plug the cables into the system card.
- 9** Plug the PCMCIA modem into the new system card.
- 10** Power on and verify the LEDs. See "Adapter LEDs" on page 1-2.
- 11** The box serial number must be written into the Vital Product Data on the new system card. Go into the firmware (see "The Firmware Interface" on page C-1) and follow the procedures for using the Utilities option.
  - a. Under Utilities, select option 9 "View or Set Vital Product Data"
  - b. Select the "Hardware Vital Product Data" option
  - c. Type in the box serial number.
- 12** Notify the network administrator that you are finished repairing the 2216.



---

## Exchanging the Hard Drive on the System Card

- 1 Remove the system card as described in steps 1 through 4 in “Exchanging the System Card” on page 3-3.

**Attention:** In the following step, be sure to support the hard drive to avoid damaging the pins when the screws are removed.

- 2 Lay the system card on a soft non-conductive surface.
- 3 On the bottom of the system card, remove the four screws (with a screw starter) while holding the hard drive in place.

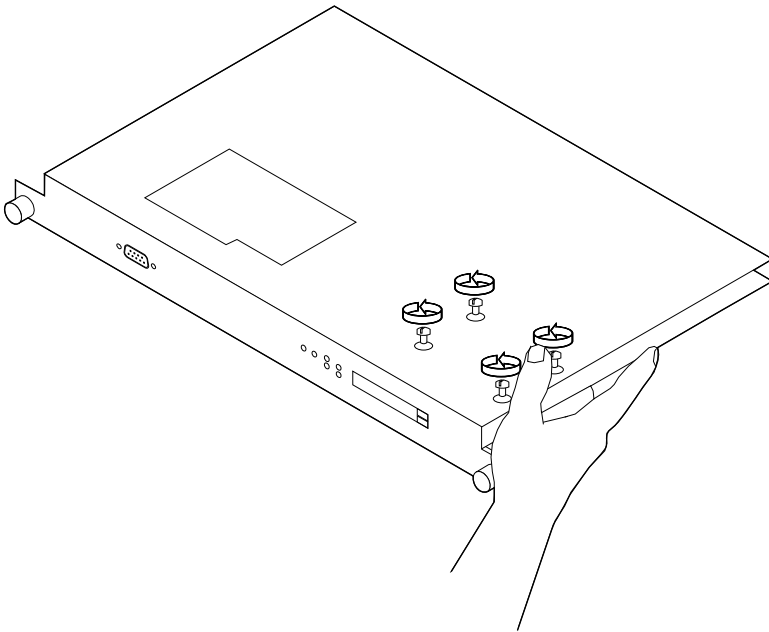

- 4 On the reverse side of the system card, disconnect the drive from the connector and lift it off the system card.

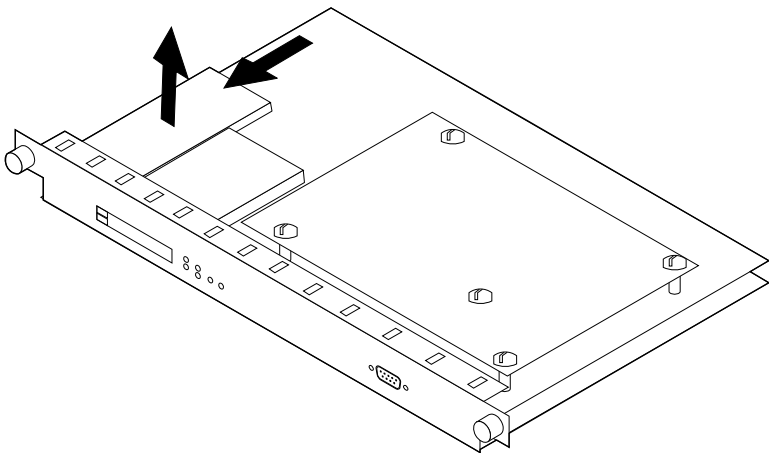

**5** Center the new hard drive inside the lines on the system card.

**Note:** If you do not center the hard drive, the electrical pins on the hard drive will be visible next to the hard drive connector on the system card. Install the new hard drive by reversing steps 3 and 4 above. Be sure to support the hard drive while installing the screws.

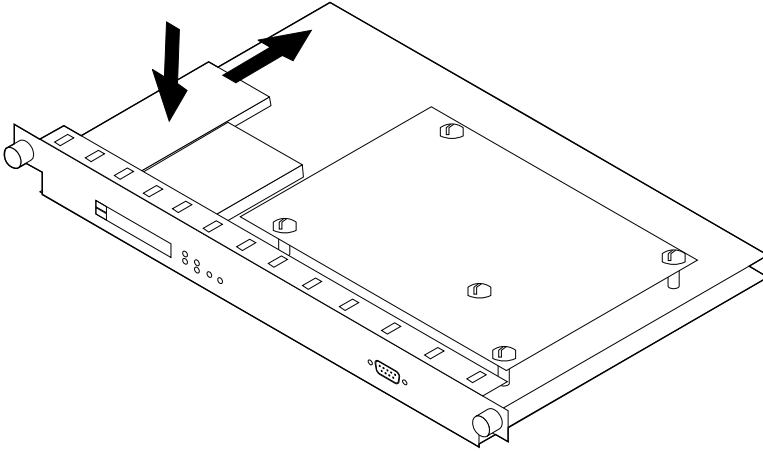

**6** Reinstall the system card as described in “Exchanging the System Card” on page 3-3.

---

## Installing Operational Software on the New Hard Drive

**Note:** This procedure should be performed by trained IBM service personnel. Customers who need this done should contact IBM service.

Follow these steps to install the operational software on the hard drive:

- 1** Restart the IBM 2216 in Attended mode or press **F1** (possibly several times) during the load sequence from a console. (See the chapter entitled “Accessing the Firmware from the Command Line Interface” in the *2216 Software User’s Guide* for additional information.) This will bring up the firmware menu “System Management Services.”
- 2** From the menu, select **Reformat Hard Drive** and press **Enter**.
- 3** When the formatting is complete, select **Create Directory Structure** and press **Enter**. The hard drive is now prepared to receive operational software files.
- 4** Select **Utilities**.
- 5** Select the *Change Management* option.
- 6** Use TFTP to transfer the complete set of operational software files from a workstation to the IBM 2216 hard drive. The following sequence of commands illustrates how this is done. You will need to substitute your own values for the IP address and path, which are given as examples. The number of bytes received is also an example. Note that you transfer the files to banks within the IBM 2216. These banks represent the directories that you have just created; you do not have to be concerned about transferring the files to a particular directory within the IBM 2216.

```
Boot config> tftp
Please specify the file type to tftp
c - config, i - image, f - firmware, o - other> i
You have chosen an image file, specify bank to write to, A, B or F> A

You cannot overwrite Bank A image; it is currently ACTIVE

You have chosen an image file, specify bank to write to, A, B or F> B

Specify the IP address of the tftp server> 1.2.3.4

Specify the path and file name to load> /usr/mas/rel2/xa.ld

Enter Y to continue, anything else to exit> Y

Transferring file...

Transfer complete; 6504322 bytes received
```

The type of file called *f* is a firmware file, which contains system diagnostics and basic utilities.

- 7** After you have successfully transferred the operational software, you must go through the configuration steps outlined in the *2216 Nways Multiaccess Connector Planning and Setup Guide*, specifically the **Set** commands.

---

## Exchanging the Fan Tray

**Attention:** The fan tray is hot pluggable; however, you must install the new tray within 3 minutes of removing the defective tray to prevent overheating the IBM 2216.

- 1 Loosen the two thumbscrews that secure the fan tray and remove the fan tray.

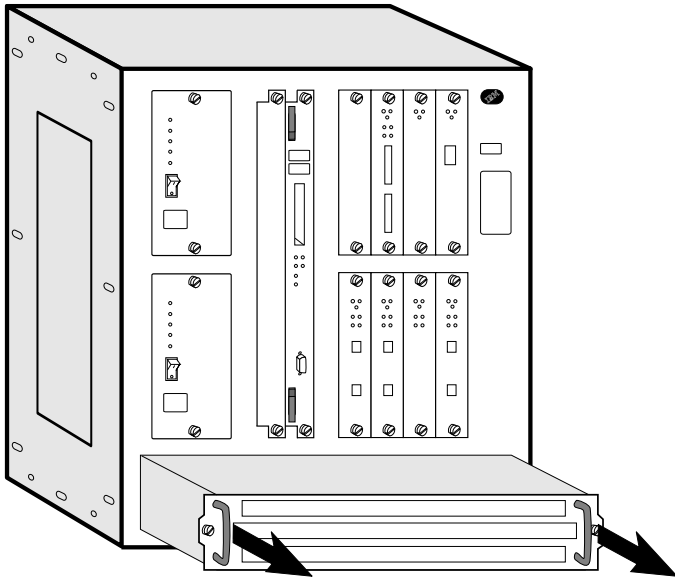

- 2 Slide the new fan tray in until the tabs on the back of the fan tray are in the slots. This aligns the connectors with the plugs.

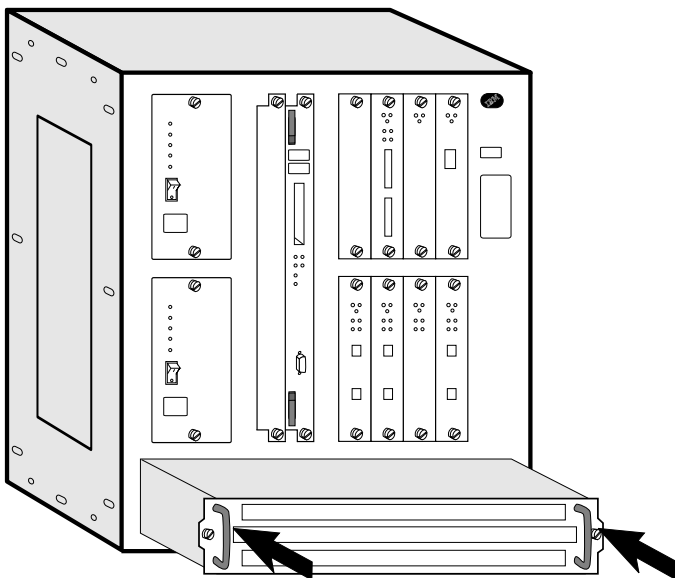

- 3 When the fan tray is flush with the box, tighten the two thumbscrews.

---

## Exchanging an Adapter

**Note:** The adapter you replace must be of the same type as the original. Otherwise, you will need to reconfigure. See the *2216 Planning Guide* and the *Software User's Guide*.

**1** Locate the adapter module to be replaced.

**Attention:**

- a. Adapters are hot pluggable, but all adapter ports must be disabled before cables are removed. See "Disabling an Adapter Port to Suspend Traffic" on page C-6.
- b. If an adapter is removed prior to disabling the ports, a machine check can occur.
- c. If you are removing a serial adapter (EIA-232E/V.24, V.35/V.36, X.21 which are LIC's 282, 290 and 291), you need to disable the WAN Reroute process before you remove the adapter. (See "Disabling Interfaces that have WAN Reroute Enabled" on page C-8.)

**2** Label the cables for proper reconnection.

**3** Loosen the screws (if present) that secure the cable or cables.

**4** Remove the cable or cables.

**Attention:** You must turn the adapter's thumbscrews simultaneously when unseating or seating the adapter during removal or installation. By doing so, you prevent stripping the thumbscrews. If you strip the thumbscrews, you may not be able to seat or reseat the adapter properly.

**5** Loosen the screws on the adapter.

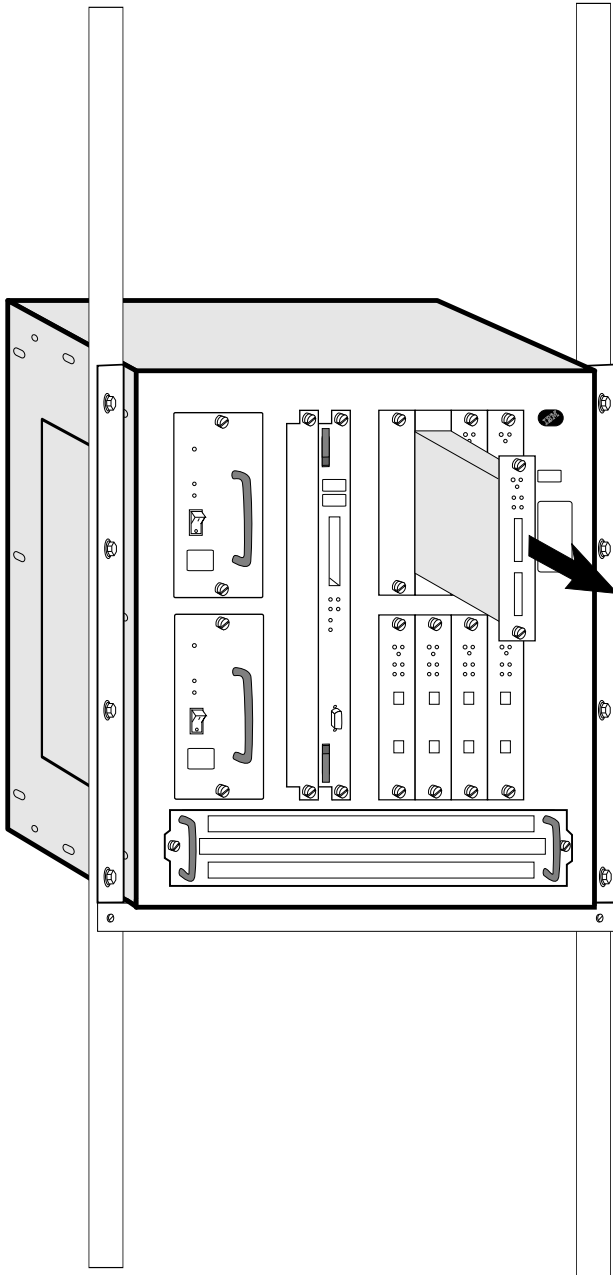

**6** Remove the adapter from its location.

**7** Insert the new adapter card into the machine. Make sure the adapter card is aligned with the plastic grooves and then slide it in until it is flush with the box.

When the card makes full contact with the rear of the IBM 2216, press and simultaneously turn each thumbscrew on the face of the adapter card clockwise, *only* until the adapter is firmly seated.

**8** Secure the module by tightening the screws.

**9** Check that the green LED of the adapter comes ON and that the Wrong Slot LED is OFF. If not, check the adapter installation. If the problem persists call the support center. Otherwise, continue.

- 10** If you are replacing/inserting a serial adapter (EIA-232E/V.24, V.35/V.36, X.21 which are LIC's 282, 290 and 291) and you went through the WAN Reroute disable procedure ("Disabling Interfaces that have WAN Reroute Enabled" on page C-8), you need to enable the WAN Reroute process. (See "Enable WAN Reroute after you have Disabled it" on page C-8).
- 11** Replace the removed cable or cables, then tighten the cable screws (if present).
- 12** Re-enable all adapter ports. See "Enabling an Adapter Port to Resume Traffic" on page C-6.

---

## Exchanging the Backplane

**Note:** This procedure requires two people.

- 1** Switch off each power supply.
- 2** Unplug the power cord from the power receptacle.
- 3** Label the cables with the adapters and ports they plug into. Unplug all the cables.
- 4** Make a note of the slot position of each card in the unit. If you have a filled-out *Hardware Configuration Quick Reference* card, this information should be already available. This card should be in the area on the underside of the IBM 2216 on the left.
- 5** The unit is too heavy when fully populated.
- 6** Remove the:
  - Power supplies (Loosen the screws on each component and pull the handle)
  - System card (see “Exchanging the System Card” on page 3-3)
  - Adapters (see “Exchanging an Adapter” on page 3-9)
  - Fan tray (see “Exchanging the Fan Tray” on page 3-8).

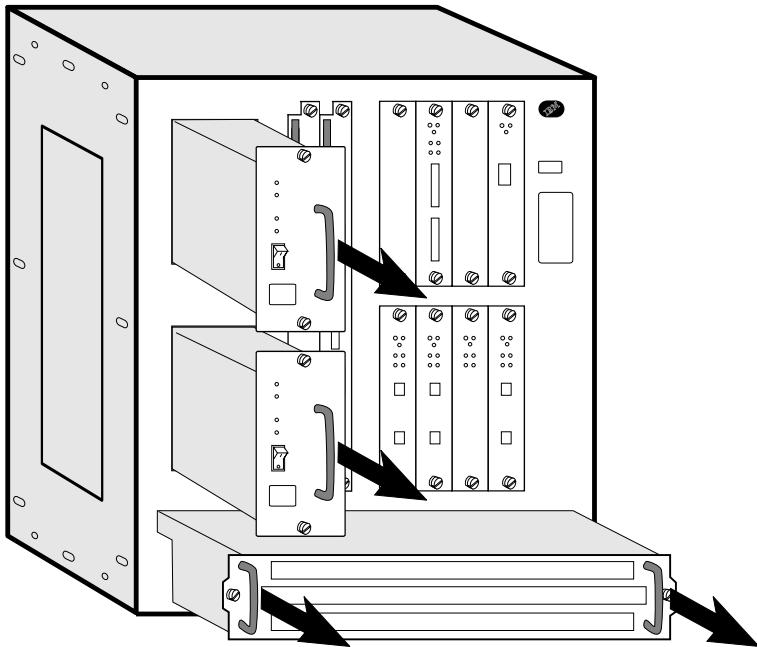

- 7** If the 2216 is installed in a rack, but not on a shelf, it is recommended that you install a shelf or the installation aid under the 2216 before removing the screws from the rack-mounting brackets.



**8** Remove the screws from the rack-mounting brackets.

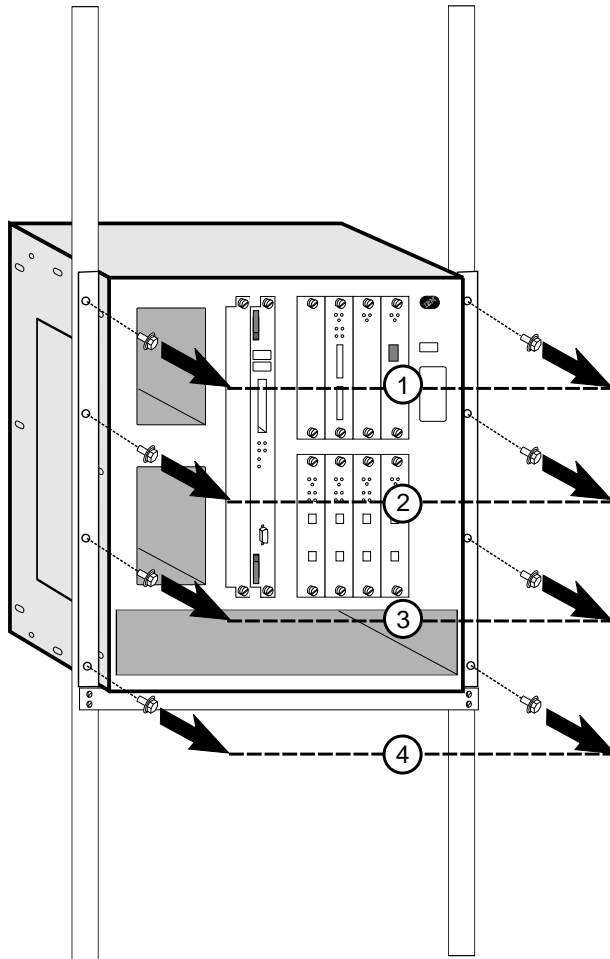

**9** Hold the 2216 from the top of the back and bottom of the front, and then slide it forward out of the rack.

**10** Place the 2216 on a table.

**11** Remove the three screws near the top of the side panels.

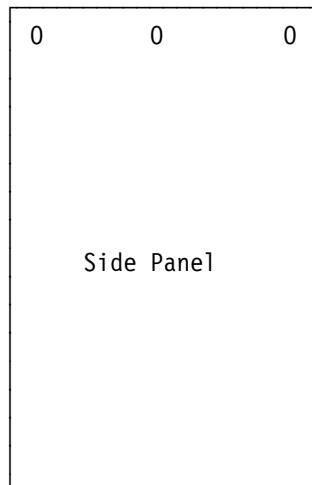

**12** Remove the top panel. To do this, go to the rear of the 2216. Lift the top panel, and then slide the panel toward you.

**13** On each side of the 2216, remove the three screws along the rear of the side panels of the 2216 that hold the backplane in place.

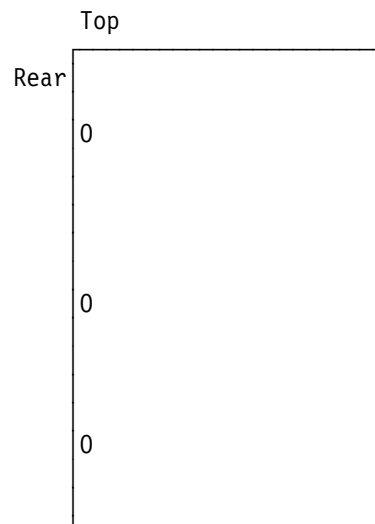

**14** Remove the eight nuts and star washers located on the inside of the 2216.

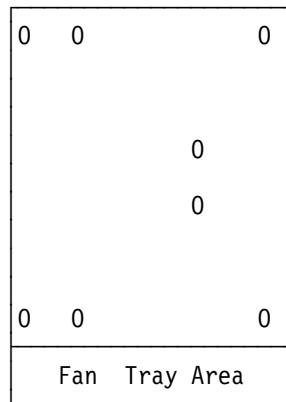

Relative locations of the nuts viewed from the front of the box

**15** Hold the backplane by the finger holes and lift it straight out of the 2216.

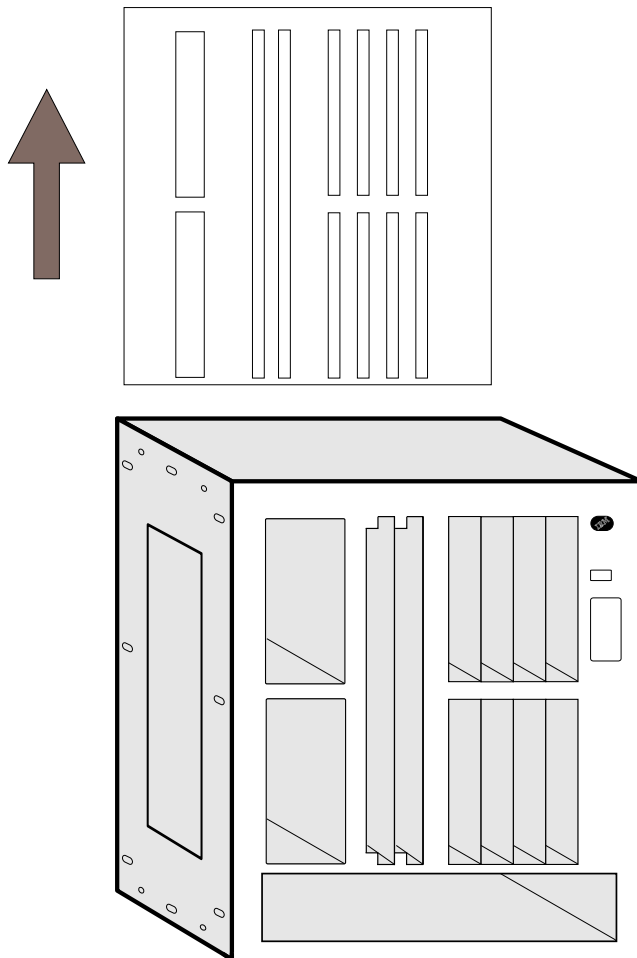

**16** Hold the new backplane by the finger holes and lower it gently into the 2216.

**17** Align the screw holes on the backplane with those on the sides of the box.

**18** Loosely install the top two screws on each side of the 2216.

- 19** Reach inside the 2216, grasp the bottom middle of the backplane's plastic shield, and press it up and toward you until all the bulkhead screws protrude through the chassis.
- 20** Loosely insert the remaining screws on each side.
- 21** Install and tighten the eight nuts and star washers inside the 2216 that secure the backplane to the system.
- 22** Tighten the screws along the side of the box that hold the backplane in place.
- 23** Replace the top of the unit.
  - a** Align the five tabs on the top panel with the slots on the top front of the 2216.
  - b** Lower the top, and then press it back into place.
  - c** Reinstall the middle screw on each side.
- 24** Reinstall and tighten the three screws that secure the top of the box to each side of the box.
- 25** Mount the 2216 in the rack. It is recommended that you use a screw starter here.
  - a** If you have a shelf, install it in the rack first. Otherwise, install the installation aid.

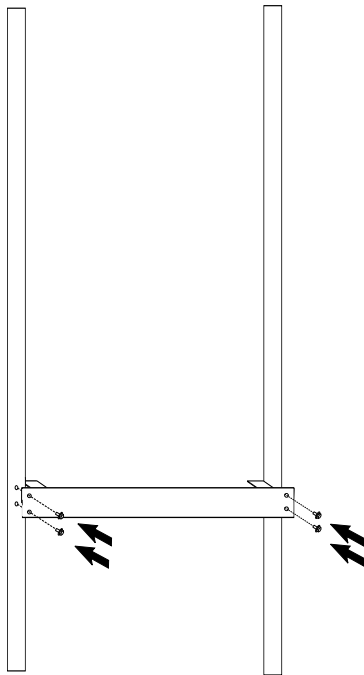

- b** Slide the 2216 into the rack.
- c** While one person holds the box in place, the other should install the bottom screw into each mounting bracket. Then install the remaining six screws.

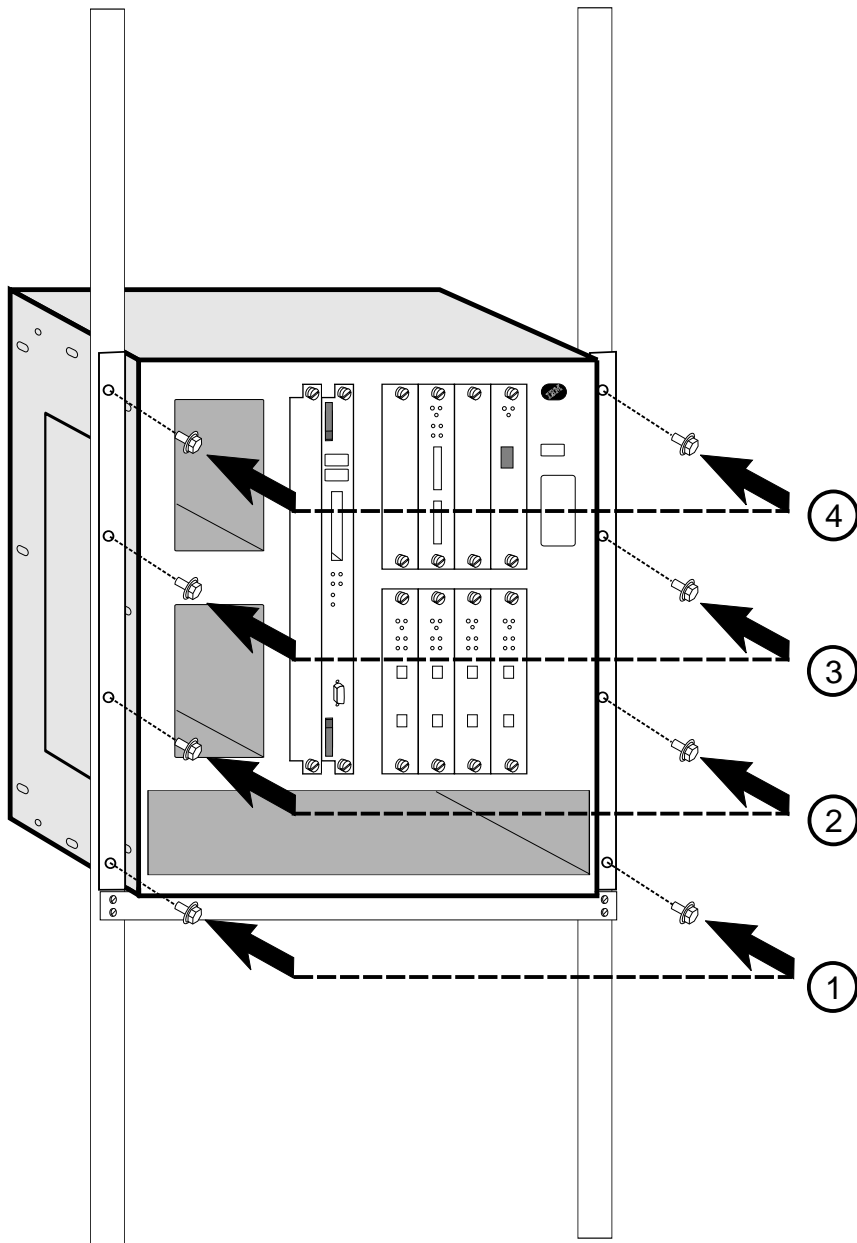

**d** Remove the shelf, if necessary.

- 26** Install the fan tray. Slide the fan tray in until the tabs on the back of the fan tray are in the slots. This aligns the connectors with the plugs. When the fan tray is flush with the box, tighten the two screws.

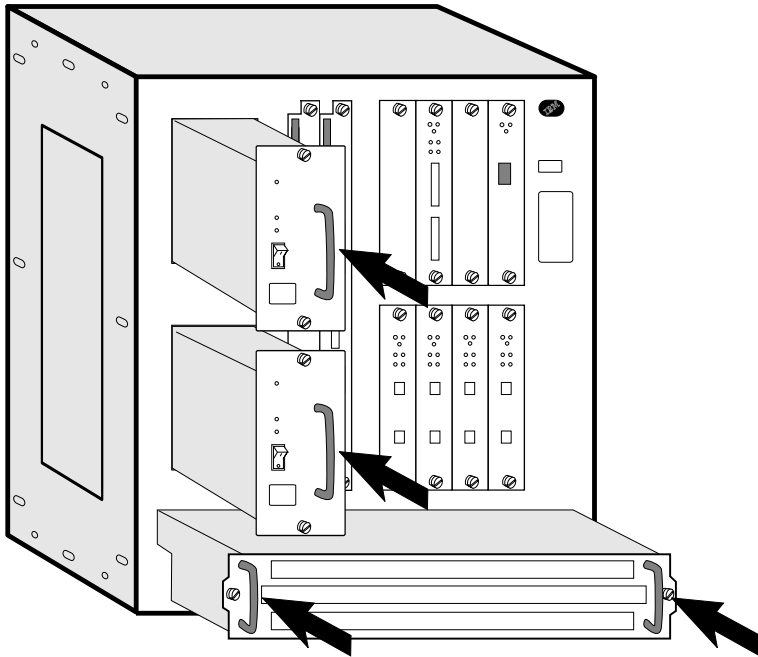

- 27** Install the slot cover into slot A.
- 28** Install the system card in slot B. Make sure the card is aligned with the plastic grooves and then slide it in until it is flush with the box. (See “Exchanging the System Card” on page 3-3 for details). Tighten the screws.
- 29** Moving from left to right, install the remaining adapters. Slide each adapter along the plastic grooves until it clicks into place. (See “Exchanging an Adapter” on page 3-9 for details.)
- 30** Finally, install the power supplies. The power supplies will slide into place by following metal rails in the box.
- 31** Connect the cables and power cord to the power receptacle.
- 32** Switch on the power.
- 33** Verify the LEDs. See “Adapter LEDs” on page 1-2.
- 34** Notify the network administrator that you are finished repairing the 2216.

---

## Chapter 4. Using IBM 2216 Firmware

The IBM 2216 firmware tests the hardware each time the IBM 2216 is powered on. If the IBM 2216 has not loaded its operational code, the firmware should be running. The firmware menu will come up and pause when the IBM 2216 is set up to boot up in "Attended Mode." Attended Mode requires direct intervention from console input to complete the boot-up process (a password is required). Attended mode can be configured from the **Talk 6** command set or from the Firmware command set.

### Important:

1. You can also access the firmware by stopping the boot process. To do this, you must have a TTY console directly attached to the serial port.
2. To access the firmware:
  - a. When the IBM 2216 starts its boot process, press **F1** at the terminal keyboard.
  - b. If the firmware panels do not appear:
    - 1) Make sure your workstation is connected to the serial port on the IBM 2216
    - 2) Restart, or power off and power on, the IBM 2216.

**Note:** Make sure the screen size for your terminal emulation software is set to 80 columns by 24 rows.

Connection in Attended mode is a TTY (using limited VT100, VT220, IBM 3151 or 3161 emulation) connection. You can transfer files using the Xmodem protocol for TTY, or TFTP for IP connections.

---

### Attended Mode

When the IBM 2216 is configured to come up in Attended mode, you are given access to the Firmware command set. (A password is required before you will have access to the firmware.) From this level of commands, you can select the Image Bank from which to load. You can also choose the config file from within that Image Bank. At this point, you can load new config files or image files.

In Attended mode, you can start booting the IBM 2216 by pressing **F9** or to start the operating system.

---

### Unattended Mode

This is the normal mode for the IBM 2216. (A password is not required to access the firmware in unattended mode.)

---

## Starting 2216 Firmware

You are ready to begin using the information in this chapter after you have prepared your service terminal (as described in the *IBM 2216 Planning Guide*) and have established connection with the IBM 2216.

The firmware menu will come up when you power on the 2216 in Attended mode or when you stop the boot process by pressing **F1**. From the menu (as shown in Figure 4-1), you can select from four services. The following sections explain these services and provide instructions for using the associated panels:

- “Managing the Configuration” on page 4-3.
- “Selecting the Boot Sequence” on page 4-4.
- “Selecting a Device To Test” on page 4-5.
- “Using the Utilities” on page 4-7.

```
Nways System Firmware
Version 1.0
(C) Copyright IBM Corporation, 1996 All Rights Reserved.
                        System Management Services

Select one:
 1. Manage Configuration
 2. Boot Sequence Selection
 3. Select Device to Test
 4. Utilities

Enter   -   Esc=Quit   -   F1=Help   -   F3=Reboot   -   F9=Start OS -
-----
```

Figure 4-1. Main Menu Panel

---

## Obtaining Help

Online helps are available for panels whenever the F1 key is displayed in the lower portion of the panel. Pressing F1 presents a pop-up help window with information relating to the currently active panel.





## Selecting the Boot Sequence

This function enables you to select a sequence for the various boot devices, display the current boot device settings, restore the default setting, and boot from other boot devices. To select a boot sequence:

- 1 Select **2. Boot Sequence Selection** from the main menu.
- 2 The Boot Sequence Selection panel is displayed as shown in Figure 4-3.

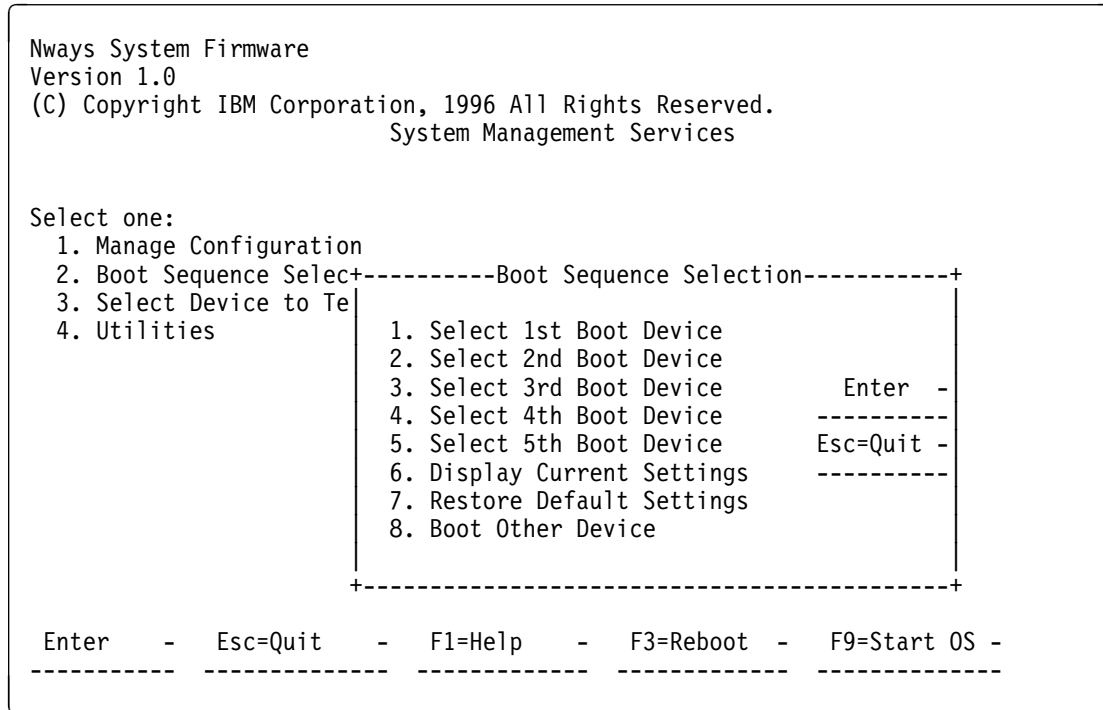

Figure 4-3. Boot Sequence Selection Panel

- 3 Select one of the options (1 through 5) and press **Enter**. The appropriate Boot Device Selection panel will be displayed. Default boot devices are:
  - None
  - IDE hard drive
  - Network adapter (IBM PCMCIA Modem)
  - Network adapter (IBM SLIP, Com 1 Direct)
- 4 Highlight your choice and press **Enter**.
- 5 Repeat step 3 and step 4 to select as many boot devices as you want to define.
- 6 Press **F3** to reboot the IBM 2216 and make your boot device change effective.
- 7 To restore the defaults, select option 7 before you reboot the IBM 2216. The default boot device settings will then be restored. The Current Boot Sequence will be displayed as in Figure 4-4 on page 4-5.

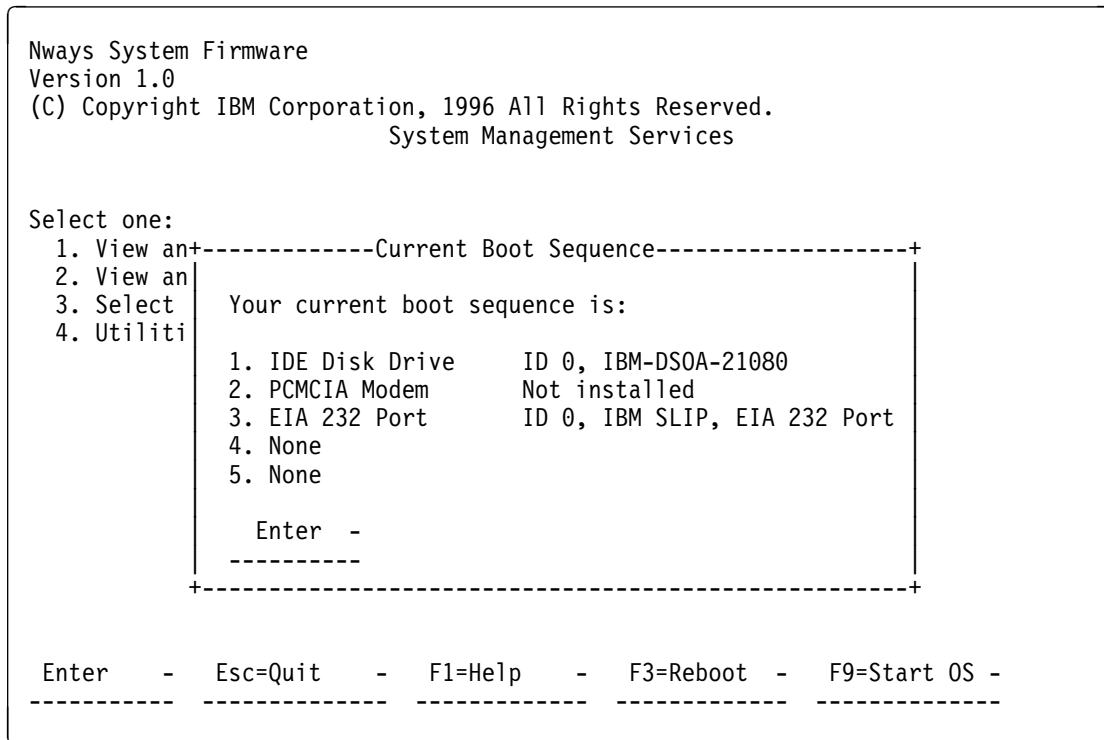

Figure 4-4. Current Boot Sequence

## Selecting a Device To Test

Extensive hardware tests are performed by the firmware when the IBM 2216 boots up. But there may be times when you have removed and replaced a failing part and you want to run an individual test before a full bootup or reset. The firmware allows you to run these individual tests:

- Test All Subsystems: This test runs all the subsystem tests that are listed on this panel.
- Test Memory: This test searches all available memory regions, tests the regions, and presents a consolidated list of test results.
- Test System Board: This tests the PowerPC CPU, the System Board interrupts, and the PCMCIA controller.

**1** Select **3. Select Device to Test** from the main menu.

**2** The Select Device to Test panel is displayed (Figure 4-5 on page 4-6).

**Note:** The Select Device to Test panel is created dynamically, depending on what diagnostics have been loaded, but the items shown will always appear.

```

Nways System Firmware
Version 1.0
(C) Copyright IBM Corporation, 1996 All Rights Reserved.
      System Management Services

Select one:
  1. View and Set Configuration
  2. View and Set B+-----Select Device to Test-----+
  3. Select Device |                                     |
  4. Utilities     |                                     |
                  |                                     |
                  | {>} Test All Subsystems           | Esc=Quit   -
                  | { } Test Memory                   | -----
                  | { } Test System Board              | F1=Help    -
                  | { } Test IDE devices                | -----
                  |                                     | Spacebar=Choose -
                  |                                     | -----
                  |                                     | F4=Parm Setup -
                  |                                     | -----
                  |                                     | F6=Execute  -
                  |                                     | -----
                  |                                     | F9=Display Error Log -
                  |                                     | -----
Enter  -
-----+-----+

```

Figure 4-5. Test Selection Panel

**3** Use the spacebar and up arrow and down arrow keys to select the test you want to run.

**4** Press **F4** to define additional test parameters.

**Note:** Errors encountered during diagnostics are logged in the hardware error log.

**5** The Test Parameters panel is displayed. From this panel you can select:

- Run Interactive Test
- Run Wrap Tests
- Stop On Error
- Loop Tests
- Loop Count

Press **Esc** to return to the Select Device to Test panel.

**6** Press **F6** to start a test.

**7** After the test is complete, press **Esc** to return to the main menu panel.

---

## Using the Utilities

To use the utilities:

- 1** Select **4. Utilities** from the main menu.
- 2** A menu listing the available utilities is displayed (Figure 4-6).

```
Nways System Firmware
Version 1.0
(C) Copyright IBM Corporation, 1996 All Rights Reserved.
                          System Management Utilities
```

Select one:

1. Set Power-On Password
  2. Set Supervisory Password
  3. Enable Unattended Start Mode
  4. Disable Unattended Start Mode
  5. Remove Power-On Password
  6. Remove Supervisory Password
  7. Update System Firmware
  8. Display Error Log
  9. View or Set Vital Product Data
  10. Copy Remote Files
  11. Remote Initial Program Load Setup
  12. Change Management
  13. Prepare Hard Disk
- Enter - Esc=Quit - F1=Help -
- 

Figure 4-6. Utilities Selection Panel

- 3** Make your selection. You will be prompted for additional information, and messages are displayed to indicate that the task was performed.

## Setting the Power-On Password

If a password is set/installed and the IBM 2216 is not in unattended mode, you must set a power-on password before operational code can be loaded in the IBM 2216. The IBM 2216 is initially shipped with a password of **2216**. This utility allows you to set and change the password.

**1** Select **1. Set Power-On Password** from the utilities panel. The Set Power-On Password panel is displayed (Figure 4-7).

**2** Type your new password and press **Enter**. You are prompted to enter your new password again.

**Note:** The power-on password can consist of from 1 to 8 characters with no restrictions on which characters can be used.

```
Nways System Firmware
Version 1.0
(C) Copyright IBM Corporation, 1996 All Rights Reserved.
                        System Management Utilities

Select one:
 1. Set Power-On Password-----Set Power-On Password-----+
 2. Set Supervisor
 3. Enable Unattended
 4. Disable Unattended
 5. Remove Power-On Password
 6. Remove Supervisor
 7. Update System
 8. Display Error
 9. View or Set Variables-----+
10. Copy Remote Files
11. Remote Initial Program Load Setup
12. Change Management
13. Prepare Hard Disk
Enter - Esc=Quit - F1=Help -
-----
```

Figure 4-7. Set Power-On Password Panel

**3** Type the password again and press **Enter**.

**4** The Password Saved panel is displayed with the message that your power-on password has been saved.

## Setting the Supervisory Password

If a supervisory password is set, the password must be entered prior being able to access to the “System Management Services.” You must set a supervisory password before operational code can be loaded in the IBM 2216. The IBM 2216 is initially shipped with a password of **2216**. This utility allows you to set and change the password.

**1** Select **2. Set Supervisory Password** from the utilities panel. The Set Supervisory Password panel is displayed (Figure 4-8).

**2** Type your new password and press **Enter**. You are prompted to enter your new password again.

**Note:** The supervisory password can consist of from 1 to 8 characters with no restrictions on which characters can be used.

```
Nways System Firmware
Version 1.0
(C) Copyright IBM Corporation, 1996 All Rights Reserved.
                        System Management Utilities

Select one:
 1. Set Power-On P+-----Set Supervisory Password-----+
 2. Set Supervisor |
 3. Enable Unatten | Type your new password, and then
 4. Disable Unatte | press Enter.
 5. Remove Power-0 |
 6. Remove Supervi |
 7. Update System | Enter - F1=Help - Esc=Quit
 8. Display Error | -----
 9. View or Set Vi+-----+
10. Copy Remote Files
11. Remote Initial Program Load Setup
12. Change Management
13. Prepare Hard Disk
Enter - Esc=Quit - F1=Help -
-----
```

Figure 4-8. Set Supervisory Password Panel

**3** Type the password again and press **Enter**.

**4** The Password Saved panel is displayed with the message that your supervisory password has been saved.

## Enabling Unattended Start Mode

The default is that Unattended start mode is enabled. This causes the IBM 2216 to load operational code automatically.

- 1** Select **3. Enable Unattended Start Mode** from the utilities panel. The Unattended Start Mode Changed panel is displayed (Figure 4-9).
- 2** Press **Enter**.

```
Nways System Firmware
Version 1.0
(C) Copyright IBM Corporation, 1996 All Rights Reserved.
                        System Management Utilities

Select one:
 1. Set Power-On Password
 2. Set Supervisor+-----Unattended Start Mode Changed-----+
 3. Enable Unatten|
 4. Disable Unatte|   Unattended start mode has been
 5. Remove Power-0|   enabled.
 6. Remove Supervi|
 7. Update System  |   Enter -
 8. Display Error  |   -----
 9. View or Set Vi+-----+
10. Copy Remote Files
11. Remote Initial Program Load Setup
12. Change Management
13. Prepare Hard Disk

Enter - Esc=Quit - F1=Help -
-----
```

Figure 4-9. Unattended Start Mode Changed (Enabled) Panel

**Note:** After you have enabled Unattended start mode, you can enter the firmware by pressing and holding **F1** at the terminal keyboard when the boot process begins.



## Disabling Unattended Start Mode

The default for the IBM 2216 firmware is that the Unattended start mode is enabled. You disable Unattended Start Mode using this utility.

- 1** Select **4. Disable Unattended Start Mode** from the utilities panel. The Unattended Start Mode Changed panel is displayed (Figure 4-10).
- 2** This panel informs you that the Unattended start mode has been disabled and prompts you to press **Enter**.

```
Nways System Firmware
Version 1.0
(C) Copyright IBM Corporation, 1996 All Rights Reserved.
                        System Management Utilities

Select one:
 1. Set Power-On Password
 2. Set Supervisory Password
 3. Enable Unatten+-----Unattended Start Mode Changed-----+
 4. Disable Unatte|
 5. Remove Power-0|   Unattended start mode has been
 6. Remove Supervi|   disabled.
 7. Update System  |
 8. Display Error  |   Enter -
 9. View or Set Vi|   -----
10. Copy Remote Fi+-----+
11. Remote Initial Program Load Setup
12. Change Management
13. Prepare Hard Disk

Enter -   Esc=Quit -   F1=Help -
-----
```

Figure 4-10. Unattended Start Mode Changed (Disabled) Panel

## Removing the Supervisory Password

The use of a supervisory password allows you a degree of security by preventing unauthorized access to the IBM 2216. However, removing the enforcement of the password could be a convenience while servicing the IBM 2216.

- 1** Select **6. Remove Supervisory Password** from the utilities panel.
- 2** The Remove Supervisory Password panel is displayed (Figure 4-11).

```
Nways System Firmware
Version 1.0
(C) Copyright IBM Corporation, 1996 All Rights Reserved.
                          System Management Utilities

Select one:
 1. Set Power-On Password
 2. Set Supervisory Password
 3. Enable Unatten+-----Remove Supervisory Password-----+
 4. Disable Unatte|
 5. Remove Power-0| Do you want to remove the
 6. Remove Supervi| Supervisory password?
 7. Update System  |
 8. Display Error  | Yes - No -
 9. View or Set Vi | -----
10. Copy Remote Fi+-----+
11. Remote Initial Program Load Setup
12. Change Management
13. Prepare Hard Disk

Enter - Esc=Quit - F1=Help -
-----
```

Figure 4-11. Remove Supervisory Password Panel

- 3** Select **Yes** if you want to remove the supervisory password. Press **Enter**.
- 4** The Password Removed panel is displayed. This panel informs you that the supervisory password has been removed.

## Updating System Firmware

Use this utility to update the IBM 2216 firmware. Only full images of the firmware are shipped; therefore, when you select this option you completely replace the previous level of firmware.

**Note:** It is important that the IBM 2216 not be powered off or reset during this process. If the update fails, the IBM 2216 will boot a backup firmware image. If this happens, repeat the update procedure to reload the onboard firmware image.

- 1** Select **7. Update System Firmware** from the utilities panel.
- 2** The System Firmware Update panel is displayed (Figure 4-12).

```
Nways System Firmware
Version 1.0
(C) Copyright IBM Corporation, 1996 All Rights Reserved.
                        System Management Utilities

Select one:
 1. Set Power-On Password
 2. Set Supervisory Password
 3. Enable Unattended Start Mode
 4. Disable Unattended Start Mode
 5. Remove Power-On+-----F/W Update Options-----+
 6. Remove Supervi|
 7. Update System | 1. TFTP a Remote Image File
 8. Display Error  | 2. XMODEM a Remote Image File
 9. View or Set Vi | 3. Use a Local Image File
10. Copy Remote Fi|
11. Remote Initial | Enter - Esc=Quit - F-1=Help
12. Change Managem| -----
13. Prepare Hard D+-----+

Enter - Esc=Quit - F1=Help -
-----
```

Figure 4-12. System Firmware Update Panel

- 3** Select the option you wish to use from those listed. The firmware update process begins. It informs you that the system firmware has been updated.

**Attention:** Do not power off the IBM 2216 during the process of updating the firmware.

## Displaying the Error Log

The error log is resident in NVRAM (not on the hard drive). See Appendix B, "Firmware Error Codes" on page B-1 to interpret the data that appears in the Error Code field.

- 1 Select **8. Display Error Log** from the utilities panel.
- 2 The Error Log panel is displayed (Figure 4-13). See Appendix B, "Firmware Error Codes" on page B-1 for an explanation of the data that appears in the Error Codes field.

The Location field can contain any of the following entries:

- PCMCIA modem
- ATM adapter Port 1
- ATM adapter Port 2
- System board

```
Nways System Firmware
Version 1.0
(C) Copyright IBM Corporation, 1996 All Rights Reserved.
                System Management Utilities

Select one:
 1. Set Power-On Password
 2. Set Supervisory Password
 3. Enable Unattended Start Mode
 4. Disable Unattended Start Mode
 5. Remove Power-On Password
-----Event Log-----+
| 1. Src      1 08/src/arp/sysex/c200/io_int.c:324      00000005,012B
| 2. Bootup  0*****                                00-01, 21 01/03/96 16:23:27
| 3. Src      1 08/src/arp/sysex/c200/io_int.c:324      00000005,012B
|
| Enter      -   Esc=Quit  -   F1=Help   -   F2=Clear Error Log -
|-----+
Enter -   Esc=Quit -   F1=Help -
-----
```

Figure 4-13. Error Log Panel

## Viewing or Setting Vital Product Data

This utility allows you to view vital product data (VPD) for the IBM 2216. The system serial number is entered at the factory, but can be changed on the panel that appears after you select to view or set the VPD.

- 1** Select **9. View or Set Vital Product Data** from the utilities panel.
- 2** The View or Set Vital Product Data panel is displayed (Figure 4-14). From this panel you can select the type of vital product data you want to view or set. The serial number field is the only field (under the "Hardware Vital Product Data" menu) that is modifiable; Firmware Part Number is only viewable.

```
Nways System Firmware
Version 1.0
(C) Copyright IBM Corporation, 1996 All Rights Reserved.
                          System Management Utilities

Select one:
 1. Set Power-On Password
 2. Set Supervisory Password
 3. Enable Unattended Start Mode
 4. Disable Unattended Start Mode
 5. Remove Power-On Password
 6. Remove Supervisory Passw
 7. Update System Firmware +-----View or Set Vital Product Data-----+
 8. Display Error Log
 9. View or Set Vital Produc
10. Copy Remote Files      | Firmware Part Number
11. Remote Initial Program L | Hardware Vital Product Data
12. Change Management
13. Prepare Hard Disk
                               Enter - Esc=Quit - F1=Help -
Enter - Esc=Quit - |-----|
-----+-----+
```

Figure 4-14. View or Set Vital Product Data Panel

- 3** For each selection, a View or Set Part Number panel is displayed that contains the part number you selected. Version number and dates are provided for the firmware and System Management Services.
- 4** If you want to view or change vital product data, select **Hardware Vital Product Data**.

**5** The hardware VPD is stored in keyword format. The following is a list of the keywords and their meanings. Depending on the configuration of your system, not all of the keywords listed are necessarily present or have meaningful values.

- AT - Main logic card type
- DS - Text description of card
- FN - FRU number
- PN - Manufacturing part number
- ML - Maintenance level
- MF - Manufacturing location
- SN - Serial number
- BF - Boot flash level and ID
- NA - Burned-in MAC Address in ASCII Format
- ZB - Burned-in MAC Address in Hex Canonical Format
- TM - Machine type and model
- F# - Feature Number
- BS - Box serial number
- RC - Recycle count
- Z0 - Vendor ID

## Copying Remote Files

This utility allows you to copy remote files from another machine into memory or into the hard file. There are two methods of file transfer: TFTP from a server using SLIP, or Xmodem over one of the serial ports. A virtual RAM disk is automatically created with a size of 600 000 bytes for storing files in memory. Files can also be stored to the hard file by appending `c:\` to the local file name.

- 1** Select **10. Copy Remote Files** from the utilities panel.
- 2** The Copy Remote Files panel is displayed (Figure 4-14 on page 4-15). From this panel, you select the method of file transfer. Subsequent panels allow you to enter the names of the files you want to copy.

```
Nways System Firmware
Version 1.0
(C) Copyright IBM Corporation, 1996 All Rights Reserved.
                        System Management Utilities

Select one:
 1. Set Power-On Password
 2. Set Supervisory Password
 3. Enable Unattended Start Mode
 4. Disable Unattended Start Mode
 5. Remove Power-On Password
 6. Remove Supervisory Password
 7. Update System Firmware
 8. Display Error Log
 9. View or Set Vital Product
10. Copy Remote Files
11. Remote Initial Program Load
12. Change Management
13. Prepare Hard Disk

Enter - Esc=Quit -

----- Copy Remote Files-----
 1. TFTP a Remote File
 2. Xmodem a Remote File

Enter - Esc=Quit - F1=Help -
-----
```

Figure 4-15. Copy Remote Files Panel

## Setting Up Remote Initial Program Load

Before you can configure an IBM 2216 in the network, it must have an IP address that is recognized within your network, and it must have the addresses of your ATM adapters. Use this utility to dial in with a BOOTP server.

This utility allows you to load this minimum information to install this device in your network so that you can send it a configuration file or otherwise communicate with it. This utility allows you to Ping the IBM 2216, after loading its minimum network parameters, to see if you can communicate with it.

- 1 Select **11. Remote Initial Program Load Setup** from the utilities panel.
- 2 The “Network Parameters” panel is displayed (Figure 4-16). From this panel, you can select to enter the IP address of the IBM 2216 and the host, input PCMCIA adapter parameters, or Ping from the IBM 2216 to the host.

```
Nways System Firmware
Version 1.0
(C) Copyright IBM Corporation, 1996 All Rights Reserved.
                          System Management Utilities

Select one:
  1. Set Power-On Password  +----- Network Parameters -----+
  2. Set Supervisory Password |
  3. Enable Unattended Start |           1. IP Parameters           |
  4. Disable Unattended Start |           2. Adapter Parameters        |
  5. Remove Power-On Password |           3. Ping                      |
  6. Remove Supervisory Passw |
  7. Update System Firmware   |
  8. Display Error Log        |
  9. View or Set Vital Produc |           Enter - Esc=Quit - F1=Help - |
 10. Copy Remote Files        |-----+
 11. Remote Initial Program Load Setup
 12. Change Management
 13. Prepare Hard Disk

Enter - Esc=Quit - F1=Help -
-----
```

Figure 4-16. Setup Remote Initial Program Load Panel

- If you select **IP Parameters**, a panel will be displayed on which you can enter:
  - Client IP Address (the IP address of the IBM 2216)
  - Server IP Address
  - Gateway IP Address
  - Subnet Mask

An IBM 2216 comes from the factory with the following default IP addresses:

<b>Client</b>	111.11.11.11
<b>Server</b>	111.11.11.10
<b>Gateway</b>	111.11.11.10
<b>Subnet mask</b>	255.255.255.0



**3** The **Ping** option allows you to test connectivity.

**Note:** Do not Ping your current terminal connection. No response will be received, but this will not indicate a problem.

## **Xmodem Software Selection in Change Management**

The Xmodem protocol is supported only from the “System Management Services” menu. To access the “System Management Services” menu, you have to either interrupt the boot-up sequence or bring up the IBM 2216 in Attended mode. The Change Management command is available from the “System Management Utilities” option of the Main Menu. From that point, the IBM 2216 will direct you as to what to transfer in and where to put the image.

**Note:** When the IBM 2216 is in firmware mode, there is no active configuration or image. Therefore, you should use caution when specifying where to write new images or configurations.

The following sample menus are associated with Xmodem download. These menus show the text that is displayed when you choose Xmodem Software from the Change Management command.

**Examples:**

```
Nways System Firmware
Version 1.0
(C) Copyright IBM Corporation, 1996 All Rights Reserved.

                                Change Management Software Control

Select one:
1. Add Description Data
2. Describe Software
3. Control Rebooting of Router
4. Control Dumping of Router
5. Copy Software
6. Erase Software
7. List Software
8. Lock Config File
9. Set Boot Information
10. TFTP Software
11. Unlock Config File
12. XMODEM Software

Enter   -   Esc=Quit -   F1=Help  -
-----
```

```
Nways System Firmware
Version 1.0
(C) Copyright IBM Corporation, 1996 All Rights Reserved.

                                Change Management Software Control

1. Add Description Data
2. Describe Software
3. Control Rebooting of Router
4. Control Dumping of Router +-----Select Type-----+
5. Copy Software           |           1. Config           |
6. Erase Software          |           2. Load Image          |
7. List Software           |           |
8. Lock Config File        |           |
9. Set Boot Informa        |           |
10. TFTP Software          |           |
11. Unlock Config Fi+-----+
12. XMODEM Software

Enter   -   Esc=Quit -   F1=Help  -
-----
```

**Examples:**

```

Nways System Firmware
Version 1.0
(C) Copyright IBM Corporation, 1996 All Rights Reserved.
      System Management Utilities

                2216 Software Control
+----- BANK A -----+-----Description-----+-----Date-----+
| IMAGE - AVAIL                |                               | -14256 Jan 1970 - |
| CONFIG 1 - PENDING           |                               | -14256 Jan 1970 - |
| CONFIG 2 - NONE              |                               | -14256 Jan 1970 - |
| CONFIG 3 - NONE              |                               | -14256 Jan 1970 - |
| CONFIG 4 - NONE              |                               | -14256 Jan 1970 - |
+----- BANK B -----+-----Description-----+-----Date-----+
| IMAGE - PENDING              |                               | -14256 Jan 1970 - |
| CONFIG 1 - NONE              |                               | 02 Jan 1994 20:39 |
| CONFIG 2 - NONE              |                               | 02 Jan 1994 20:41 |
| CONFIG 3 - NONE              |                               | 1994 20:43        |
| CONFIG 4 - NONE              |                               | 1994 20:45        |
+-----+-----+-----+
* - Last Used Config          L - Config F          Enter
                               1. Bank A          -----
                               2. Bank B          Esc=Quit
                               -----
Enter - Esc=Quit - F1=Help -          F1=Help
-----+-----+-----+

```

```

Nways System Firmware
Version 1.0
(C) Copyright IBM Corporation, 1996 All Rights Reserved.
      System Management Utilities

                2216 Software Control
+-----+-----+
|          BANK A          |          BANK B          |
| IMAGE - PENDING         | IMAGE - AVAIL           |
| CONFIG 1 - PENDING      | CONFIG 1 - NONE         |
| CONFIG 2 - NONE         | CONFIG 2 - NONE         |
| CONFIG 3 - NONE         | CONFIG 3 - NONE         |
| CONFIG 4 - NONE         | CONFIG 4 - NONE         |
+-----+-----+
                               +Select Destination Config+
XMODEM Software              |                               |
                               |                               |
                               | Config 1          Enter - |
                               | Config 2          ----- |
                               | Config 3          ----- |
                               | Config 4          ----- |
                               |                               |
Enter - Esc=Quit - F1=Help - |                               |
-----+-----+-----+

```



---

## Chapter 5. Using Operational Diagnostics

Operational diagnostics for the IBM 2216 can be invoked through the command line interface.

In addition to using a local terminal connection, the command line interface can be invoked by a network administrator or the IBM Support Center using remote connection.

If the IBM 2216 is not configured (booted up and in config-only mode), operational diagnostics cannot be invoked.

General procedures for invoking Operational Diagnostics are described in this section.

If you access the IBM 2216 through the command line interface:

- 1** At the asterisk (\*), type **diags** and press **Enter**.
- 2** The Diagnostics Menu appears (Figure 5-1). To make your selection, type in the number of your choice and press **Enter**.

```
DIAGNOSTICS MENU

Select from the following list of functions:

<1. The Device Status Page>
  shows operational and diagnostic status for each of the installed adapters.
  From this page you can also link to the Test Control Page for each adapter.

<2. The Diagnostic Test History Log>
  contains a summary of recent testing activity.

<3. The Diagnostic Error Log>
  contains error information for recent diagnostic test that have
  detected errors.

-----
First time users should review the <4.Introduction> to using the diagnostics.

Select (1-4 or E=Exit Diagnostics):
```

Figure 5-1. Operational Diagnostics Main Menu

- To check the status of the adapters in the IBM 2216 select **<1. View Device Status>**.
- To check the contents of the test log, select **<2. View Hardware Test Log>**, or to see entries in the error log, select **<3. View Hardware Error Log>**.

Additional panels are displayed based on your selections. For example, if you select **<1. View Device Status>**, the Device Status panel (similar to the one in Figure 5-2 on page 5-2) appears.

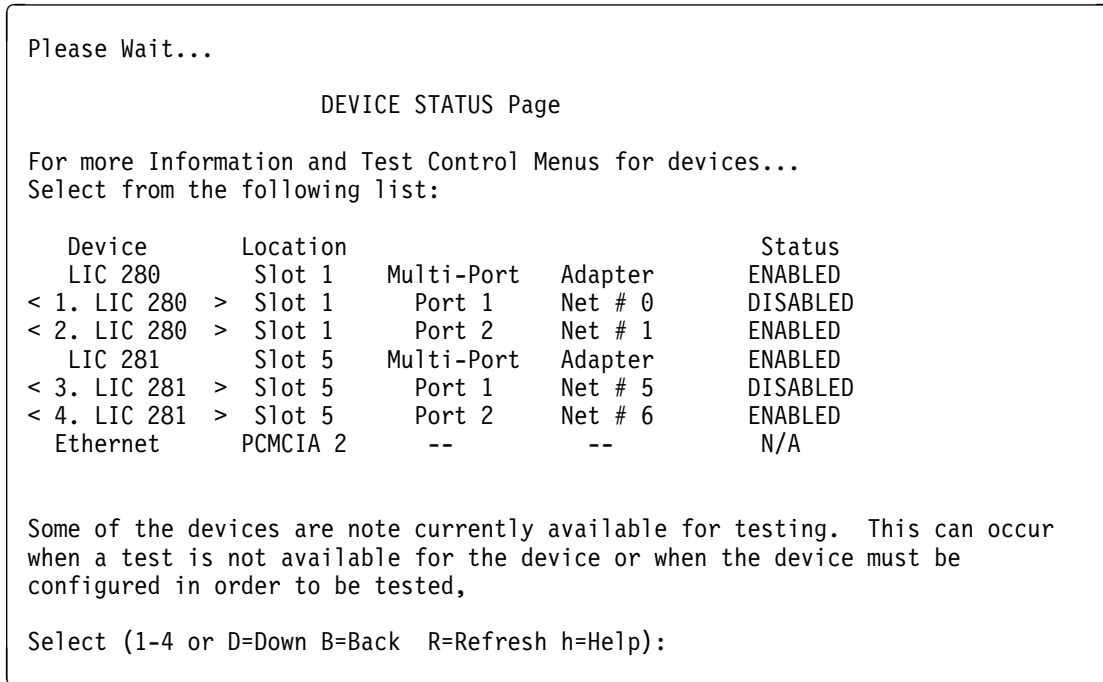

Figure 5-2. Device Status Panel Showing an ATM Interface

- 3** If you select the ATM interface (<1. **ATM lfc**> on the Device Status panel), a Test Control panel appears (Figure 5-3).

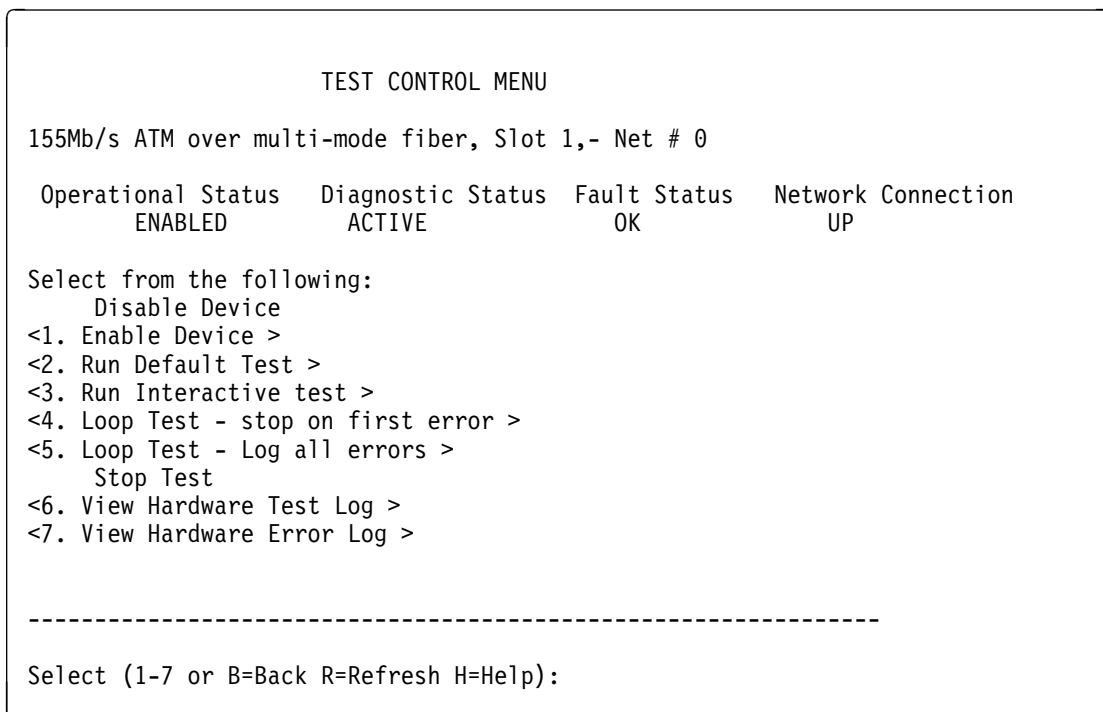

Figure 5-3. Test Control Panel (Device Enabled)

The content of the Test Control Panel is dynamically built and displayed depending on the state of the device (that is, whether it is enabled or disabled).

- If the device is enabled, the content of the Test Control panel would appear as in Figure 5-3.
- If the device is disabled, the content of the Test Control panel would appear as in Figure 5-4.

```

                                TEST CONTROL

                                Operation Diagnostics Fault Status Network Connection
                                DISABLED INACTIVE NETWORK DOWN

Select from the following;

<1. Enable Device>
<2. Run Default Test>
<3. Test Until Error>
<4. Loop and Log>
<5. View Hardware Test Log>
<6. View Hardware Error Log>

-----
<7.Diagnostics> - <8.Device Status> - <9.Refresh>

```

Figure 5-4. Test Control Panel (Device Disabled)

**Note:** You must disable a device before you test it. When the Test Control panel is displayed and the status for the device is Enabled, you can disable the device by selecting the Disable option. Once the test is complete, enable the device before exiting the diagnostics utility.

Always select **Refresh** to ensure a test is stopped before enabling a device.

**4** From this Test Control panel, you can select one of the following options:

**<1. Enable Device>**

to enable an adapter.

**<2. Run Default Test>**

to execute the default diagnostics for the adapter.

**<3. Test Until Error>**

to execute diagnostics on an adapter until an error is detected or you stop the test.

**<4. Loop and Log>**

to execute diagnostics on an adapter and log the errors detected. Select stop test to stop the diagnostics.

**<5. View Hardware Test Log>**

to display start/stop times of all operational diagnostics.

**<6. View Hardware Error Log>**

to display hardware error messages produced by operational diagnostics.

**5** Type **E** and press **Enter** to return to the command line interface prompt (\*).





---

## Appendix A. Notices

References in this publication to IBM products, programs, or services do not imply that IBM intends to make these available in all countries in which IBM operates. Any reference to an IBM product, program, or service is not intended to state or imply that only IBM's product, program, or service may be used. Subject to IBM's valid intellectual property, or other legally protectable rights, any functionally equivalent product, program, or service that does not infringe any of IBM's intellectual property rights may be used instead of the IBM product, program, or service. The evaluation and verification of operation in conjunction with other products, except those expressly designated by IBM, are the user's responsibility.

IBM may have patents or pending patent applications covering subject matter in this document. The furnishing of this document does not give you any license to these patents. You can send license inquiries, in writing, to:

IBM Director of Licensing  
IBM Corporation  
500 Columbus Avenue  
Thornwood, NY 10594 USA

---

## Electronic Emission Notices

### Federal Communications Commission (FCC) Statement

**Note:** This equipment has been tested and found to comply with the limits for a Class A digital device, pursuant to Part 15 of the FCC Rules. These limits are designed to provide reasonable protection against harmful interference when the equipment is operated in a commercial environment. This equipment generates, uses, and can radiate radio frequency energy and, if not installed and used in accordance with the instruction manual, may cause harmful interference to radio communications. Operation of this equipment in a residential area is likely to cause harmful interference, in which case the user will be required to correct the interference at his own expense.

Properly shielded and grounded cables and connectors must be used in order to meet FCC emission limits. IBM is not responsible for any radio or television interference caused by using other than recommended cables and connectors or by unauthorized changes or modifications to this equipment. Unauthorized changes or modifications could void the user's authority to operate the equipment.

This device complies with Part 15 of the FCC Rules. Operation is subject to the following two conditions: (1) this device may not cause harmful interference, and (2) this device must accept any interference received, including interference that may cause undesired operation.

## FCC Part 68 Compliance Information:

Features and optional adapters for the IBM 2216 comply with Part 68 of the FCC rules. The label included on the adapter tray contains, among other information, the FCC registration number and Ringer Equivalence Number (REN), if applicable for this equipment. If requested, provide this information to your telephone company.

The features and adapters included are:

Feature Code	Part Name
<b>2283</b>	1-Port ISDN PRI (T1/J1) Adapter LIC 283 with interface code 04DU9-1SN, service code 6.0N and jack type RJ48C.

The REN is useful to determine the quantity of devices you may connect to your telephone line and still have those devices ring when your number is called. In most, but not all areas, the sum of the RENs of all devices should not exceed five (5.0). To be certain of the number of devices you may connect to your line, as determined by the REN, you should call your local telephone company to determine the maximum REN for your calling area.

If the IBM 2216 causes harm to the telephone network, the Telephone Company may discontinue your service temporarily. If possible, they will notify you in advance. But if advance notice isn't practical, you will be notified as soon as possible. You will be advised of your right to file a complaint with the FCC.

Your telephone company may make changes in its facilities, equipment, operations, or procedures that could affect the proper operation of your equipment. If they do, you will be given advance notice so as to give you an opportunity to maintain uninterrupted service.

If trouble is experienced with this equipment, for repair or warranty information, in the United States, call IBM at **1-800-IBM-SERV**. In Canada, call IBM at **1-800-465-6600**.

No repairs can be performed by the customer.

## Industry Canada Compliance Statement

This digital apparatus does not exceed the Class A limits for radio noise emissions from digital apparatus as set out in the interference-causing equipment standard entitled: *Digital Apparatus*, ICES-003 of Industry Canada.

## Avis de conformité aux normes d'Industrie Canada

Cet appareil numérique respecte les limites de bruits radioélectriques applicables aux appareils numériques de Classe A prescrites dans la norme sur le matériel brouiller: *Appareils numériques*, NMB-003 édictée par Industrie Canada.

## Industry Canada Information:

NOTICE: The Industry Canada label identifies certified equipment. This certification means that the equipment meets certain telecommunications network protective,

operational and safety requirements. Industry Canada does not guarantee the equipment will operate to the user's satisfaction.

Before installing this equipment, users should ensure that it is permissible to be connected to the facilities of the local telecommunications company. The equipment must also be installed using an acceptable method of connection. In some cases, the company's inside wiring associated with a single line individual service may be extended by means of a certified connector assembly (telephone extension cord). The customer should be aware that compliance with the above conditions may not prevent degradation of service in some situations.

Repairs to certified equipment should be made by an authorized Canadian maintenance facility designated by the supplier. Any repairs or alterations made by the user to this equipment, or equipment malfunctions, may give the telecommunications company cause to request the user to disconnect the equipment.

Users should ensure for their own protection that the electrical ground connections of the power utility, telephone lines and internal metallic water pipe system, if present, are connected together. This precaution may be particularly important in rural areas.

**CAUTION:** Users should not attempt to make such connections themselves, but should contact the appropriate electrical inspection authority, or electrician, as appropriate.

**AVIS :** L'étiquette d'Industrie Canada permet d'identifier un équipement homologué. Cette homologation signifie que cet équipement satisfait certaines exigences en matière de protection, d'exploitation et de sécurité du réseau de télécommunications. Industrie Canada n'offre aucune garantie que le fonctionnement de cet équipement soit à la satisfaction de l'utilisateur.

Avant d'installer cet équipement, l'utilisateur doit s'assurer qu'il a la permission de le raccorder aux installations de l'entreprise de télécommunications. L'installation de cet équipement doit aussi se faire selon un mode de raccordement acceptable. Dans certains cas, le câblage interne de l'entreprise associé au service individuel offert par une ligne d'abonné peut être prolongé au moyen d'un connecteur homologué (prolongateur de téléphone). Le client devrait être informé que la conformité de son équipement aux conditions susmentionnées n'est pas une prévention contre la dégradation du service dans certaines situations.

Toute réparation d'un équipement homologué devrait être effectuée par un service de maintenance canadien autorisé qui a été désigné par le fournisseur. Toute réparation ou modification d'équipement faite par l'utilisateur, ou tout mauvais fonctionnement, pourrait entraîner la déconnexion de cet équipement par l'utilisateur à la demande de l'entreprise de télécommunications.

Pour sa protection personnelle, l'utilisateur devrait s'assurer que les mises à la terre des services publics électriques, des lignes téléphoniques et du système interne des canalisations d'eau à tuyaux métalliques, advenant leur présence, sont interconnectées. Dans les zones rurales, il s'agit-là d'une précaution particulièrement importante à prendre.

ATTENTION : Toute tentative de connexion par l'utilisateur est à déconseiller. Il est préférable de communiquer avec le responsable de l'inspection en électricité ou un électricien, selon le cas.

## **European Community (EC) Mark of Conformity Statement**

This product is in conformity with the protection requirements of EC Council Directive 89/336/EEC on the approximation of the laws of the Member States relating to electromagnetic compatibility. IBM cannot accept responsibility for any failure to satisfy the protection requirements resulting from a non-recommended modification of the product, including the fitting of non-IBM option cards.

A typical host which conforms to the protection requirements of EC Council Directive 89/336/EEC on the approximation of the law of the Member States relating to electromagnetic compatibility will continue to conform when this product is installed and operated in it.

Operation of this product in a domestic/residential environment may cause radio interference, which the user may be required to take measures to suppress.

A Declaration of Conformity with the requirements of the Directive has been signed by IBM Spain, Division of Fabricacion, 46185 La Pobla de Vallbona, Valencia, Spain.

The product bears the Telecom CE mark (CE 168 X) for ISDN Basic Rate complying with I-CTR3 (Bridging measures) as per the European directive 91/263/EEC (TTE directive). The product bears the Telecom CE mark (CE 168 X) for: V.24/V.28,V36 and X.21 electrical interfaces complying with NET 1 and with NET 2 physical level. ISDN Basic Rate complying with I-CTR3 (Bridging measures) as per the European directive 91/263/EEC (TTE directive).

This product has been tested and found to comply with the limits for Class B Information Technology Equipment according to CISPR 22 / European Standard EN 55022. The limits for Class B equipment were derived for typical residential environments to provide reasonable protection against interference with licensed communication devices.

Dieses Gerät ist berechtigt in Übereinstimmung mit dem deutschen EMVG vom 9.Nov.92 das EG-Konformitätszeichen zu führen. Der Außsteller der Konformitätserklärung ist die IBM Spain, Division of Fabricacion, 46185 La Pobla de Vallbona, Valencia, Spain.

Dieses Gerät erfüllt die Bedingungen der EN 55022 Klasse B.

## **Japanese Voluntary Control Council for Interference (VCCI) Statement**

This equipment is Class 1 Equipment (information equipment to be used in commercial and industrial districts) which is in conformance with the standard set by the Voluntary Control for Interference Council by Data Processing Equipment and Electronic Office Machines (VCCI) with an aim to prevent radio interference in commercial and industrial districts. This equipment could cause interference to radio and television receivers when used in and around residential districts. Please handle the equipment properly according to the instruction manual.

## 情報処理装置等電波障害自主規制協議会 (VCCI) 表示

この装置は、第一種情報装置(商工業地域において使用されるべき情報装置)で商工業地域での電波障害防止を目的とした情報処理装置等電波障害自主規制協議会(VCCI)基準に適合しております。

従って、住宅地域またはその隣接した地域で使用すると、ラジオ、テレビジョン受信機等に受信障害を与えることがあります。

取扱説明書に従って正しい取り扱いをして下さい。

## Korean Communications Statement

Please note that this device has been approved for business purpose with regard to electromagnetic interference. If you find this is not suitable for your use, you may exchange it for a non-business purpose one.

대한민국 통신문

이 기기는 업무용으로 전자장해능정을 받은 기기이며, 이 기기를 이 점을 주의하시기 바라며, 만약 잘못 구입하였을 때에는 구입한 곳에서 비업무용으로 교환하시기 바랍니다.

---

## Trademarks

The following terms, denoted by an asterisk (\*), used in this publication, are trademarks or service marks of IBM Corporation in the United States or other countries:

IBM	Nways	OS/2
AT	XGA	NetView
RETAIN	Presentation Manager	AIXwindows
RS/6000	PS/2	OS/2
Personal System/2	Operating System/2	

Other company, product, and service names, which may be denoted by a double asterisk (\*\*), may be trademarks or service marks of others.



## Appendix B. Firmware Error Codes

The error log that is displayed when you use the Displaying the Error Log firmware utility (see “Displaying the Error Log” on page 4-14) contains error codes. This appendix contains explanations for those error codes.

Error Code	Physical Location	Software Subsystem	Explanation
00010000	Processor	Processor	Processor Test Failure
00011000	PPC Board	NVRAM	128KB Non-volatile RAM Test Failure
00015001	PPC Board	Flash	An error occurred while erasing the system firmware.
00015002	PPC Board	Flash	An error occurred while updating the system firmware.
00015500	PPC Board	Interrupts	PPC board interrupt test failure.
00015501	PPC Board	Interrupts	Interrupt test of the processor's timing register failed.
00015502	PPC Board	Interrupts	Interrupt test of the PPC board clock failed.
00015503	PPC Board	Interrupts	Interrupt test of the PPC board programmable timer failed.
00016002	PPC Board	RTC-NVRAM	Read/Write test failure for PPC board clock.
00017001	PPC Board	Security	CMOS Battery drained. Replace RTC/8KB NVRAM.
00017002	PPC Board	Security	CMOS Error—data is gone. Replace RTC/8KB NVRAM.
00017003	PPC Board	Security	Power Interruption during last boot sequence update.
00017007	PPC Board	Security	Maximum unsuccessful attempts to enter password was reached. Time and date are logged.
00020000	Memory	Memory	Memory test error; run further tests.
000210y0	SIMM slot y	Memory	Memory error with SIMM slot y (where y=1 or 2); 1=U13 2=U14.
000210y0	SIMM slot y	Memory	Memory error with SIMM slot y (where y=1 or 2); 1=U13 2=U14.
01291000	L2 Cache	L2 Cache	For later release
1msceddd	PPC Board	Octal Uart	Octal Uart error.
2msceddd	PPC Board	I <sup>2</sup> C	I <sup>2</sup> C controller, bus, or device error
3msceddd	PPC Board	GCOM	GCOM controller error
5msceddd	PPC Board	PCMCIA	PCMCIA controller error
50000000	PPC Board	PCMCIA	PCMCIA controller error
80001300	—	Flash	Firmware update file is at the same level as current firmware. Update canceled.
80001400	—	Flash	Firmware update file does not support this system. Update canceled.
80001500	—	Flash	The firmware update file is corrupted. Update canceled.
80001600	—	Flash	The firmware update file is corrupted. Update canceled.
80001700	—	Flash	See 80001500.
80001700	—	Flash	See 80001500.
80001800	—	Flash	A valid firmware update file cannot be located. Update canceled.
80001900	—	Flash	See 80001500.
80002100	—	Flash	The firmware update file cannot be loaded. Update canceled.
80002400	—	Flash	See 80001400
80002500	—	Flash	See 80001400
90001600	—	Copy Utility	Not enough VDISK space. Unable to copy files.





---

## Appendix C. Common Tasks

This appendix provides a series of questions and answers dealing with common IBM 2216 installation, operation, and maintenance tasks, with suggestions as to where to find further help in performing them.

### LED States / Adapter Status

**Question** How do I check the states of the adapters in my IBM 2216?

**Answer** The correct LED states are displayed in the *Hardware Installation Guide*. Also, the *Maintenance Guide* treats problem determination in more detail.

### The Firmware Interface

**Question** What is the firmware interface? How do I access it?

**Answer** The firmware is the microcode lying underneath the operational code running on the 2216. It is used primarily by service personnel in problem determination. The firmware is accessed by booting the IBM 2216 and stopping the boot process with the **F1** key. It displays a menu with a number of options. Briefly, you should have a VT220 terminal with the following settings: 19.2 Kbps, 8-N-1. You can use a null modem cable for local access or a modem attachment for remote access.

Refer to the chapter entitled "Accessing the IBM 2216" in the *2216 Maintenance Guide* for more information.

### Command Line Interface

**Question** How do I access the command line interface (the operating code)?

From within the **firmware menu system** ("System Management Services"):  
Press **F9**. The \* prompt is displayed after the system boots.

The command line interface is described in the *Multiprotocol Access Services Software User's Guide*.

### Displaying List of Active Interfaces

**Question** How do I display a list of active interfaces?

**Answer**

- 1** Access the command line interface (the \* prompt).
- 2** Type **talk 6** and press **Enter** twice to reach the Config> prompt.
- 3** Enter **list dev**.
- 4** Press **Ctrl-p** to return to the command line interface.

## Displaying the Operational State of the Interfaces

**Question** How do I see the state (up, down, disabled, etc.) of an interface?

**Answer**

- 1 Access the command line interface (the \* prompt).
- 2 Type **talk 5** and press **Enter** twice to reach the + (monitoring) prompt.
- 3 Enter **configuration**.
- 4 Press **Ctrl-p** to return to the command line interface.

## Verifying Connectivity

**Question** How do I verify that a given IP address is online?

**Answer**

- 1 Access the command line interface (the \* prompt).
- 2 Type **talk 5** and press **Enter** twice to reach the + prompt.
- 3 Type **protocol** and press **Enter**.
- 4 Type **ip** and press **Enter**. The prompt changes to IP>.
- 5 Type **ping IP address value** and press **Enter**. Press **Enter** to stop the ping process.
- 6 Type **exit** at the IP> prompt and press **Enter**. The prompt changes to +.
- 7 Press **Ctrl-p** to return to the command line interface.

## Viewing Vital Software Data

**Question** How do I view vital software data?

**Answer**

- 1 At the \* prompt, type **talk 6** and press **Enter** twice. The Config> prompt appears.
- 2 Enter **boot**.
- 3 Enter **describe**. The vital software data is displayed.
- 4 Press **Ctrl-p** to return to the command line interface.

## Viewing Vital Hardware Data

**Question** How do I view vital hardware data?

**Answer**

- 1** Access the firmware main menu: During boot-up, press **F1** at the Prematurely terminate boot sequence prompt.
- 2** Select **4. Utilities**.
- 3** Select **9. View or Set Vital Product Data**.
- 4** Select **Hardware Vital Product Data**. The vital hardware data is displayed.
- 5** Return to the firmware main menu.
- 6** Press **F9** to load the operating software.

## Adding an Adapter at Initial Configuration

**Question** How do I add an adapter when the IBM 2216 is being initially configured?

**Answer** First, perform hardware installation of the adapter as described in the chapter entitled “IBM 2216 FRU Exchange” in the *IBM 2216 Maintenance Guide*. Then:

- 1** Access the command line interface (\* prompt).
- 2** Type **talk 6** and press **Enter** twice to reach the Config> prompt.
- 3** Enter **add device** *type of device*.  
For example, **add device x21**
- 4** Enter the device slot number (1–8).
- 5** If you are adding an interface on a single-port adapter, go to step 6. Otherwise, continue with this step. Enter the port number (0–7, depending on the type of adapter).

The range of port numbers supported depends on the multi-port adapter type:

- For the Token-Ring (FC 2280) and Ethernet (FC 2281) adapters, port numbers 1 and 2 are supported.
- For the 8-port EIA-232E/V.24 (FC 2282) and 8-port X.21 adapters, port numbers 0–7 are supported.
- For the 6-port V.35/V.36 (FC 2290) adapter, port numbers 0–5 are supported.

- 6** Make a note of the interface number to which this port is assigned and the net number.

Repeat steps 3 to 6 if you have a multi-port adapter and you want to have more than one interface defined on that adapter.

**Note:** The steps only create the interface. You still have to use the **net** command to configure characteristics unique to that interface (e.g. T/R, Ethernet, PPP, FR, SDLC, X.25, etc.). You also need to use the **protocol** command to configure protocols on the interface.

## Adding an Adapter after Initial Configuration

**Question** How do I add an adapter after the IBM 2216 has been initially configured?

**Answer** First, perform hardware installation of the adapter as described in the chapter entitled “IBM 2216 FRU Exchange” in the *IBM 2216 Maintenance Guide*. Then:

- 1** Access the command line interface (\* prompt).
- 2** Type **talk 6** and press **Enter** twice to reach the Config> prompt.
- 3** Enter **add device** *type of device*.  
For example, **add device x21**  
  
The following two steps do not apply when a dial-circuit device is being added.
- 4** Enter the device slot number (1–8).
- 5** If you are adding an interface on a single-port adapter, go to step 6. Otherwise, continue with this step. Enter the port number (0–7, depending on the type of adapter).  
  
The range of port numbers supported depends on the multi-port adapter type:
  - For the Token-Ring (FC 2280) and Ethernet (FC 2281) adapters, port numbers 1 and 2 are supported.
  - For the 8-port EIA-232E/V.24 (FC 2282) and 8-port X.21 adapters, port numbers 0–7 are supported.
  - For the 6-port V.35/V.36 (FC 2290) adapter, port numbers 0–5 are supported.
- 6** Make a note of the interface number to which this port is assigned and the net number.
- 7** Enter **net** *net number* to enable you to configure interface-unique characteristics.
- 8** Enter **write** to save your changes.
- 9** Reboot the IBM 2216 to make the configuration changes active.

For details of this procedure, refer to the *Multiprotocol Access Services Software User's Guide*.

## Running Quick Configuration

**Question** How do I run the Quick Configuration program?

**Answer** First, make sure each adapter has been “added” (see “Adding an Adapter at Initial Configuration”). Then, at the Config (only) prompt, enter **qc**.

## Disabling an Adapter Port

**Question** How do I disable a configured adapter port?

**Answer**

- 1** Access the command line interface (\* prompt).
- 2** Type **talk 6** and press **Enter** twice to reach the Config> prompt.
- 3** Enter **list device**.
- 4** Make a note of the interface number of the adapter you wish to disable.
- 5** Enter **disable interface** *interface number*.
- 6** Enter **write** to save your changes.
- 7** Reboot the IBM 2216 to make the configuration changes active.

For details of this procedure, refer to the *Multiprotocol Access Services Software User's Guide*.

## Enabling an Adapter Port

**Question** How do I enable a configured adapter port that was disabled using **disable interface** (in “Disabling an Adapter Port”)?

Use this procedure to enable the port the next time that you reboot the 2216.

**Answer**

- 1** Access the command line interface (\* prompt).
- 2** Type **talk 6** and press **Enter** twice to reach the Config> prompt.
- 3** Enter **list device**.
- 4** Make a note of the interface number of the adapter you wish to enable.
- 5** Enter **enable interface** *interface number*.
- 6** Enter **write** to save your changes.
- 7** Reboot the IBM 2216 to make the configuration changes active.

For details of this procedure, refer to the *Multiprotocol Access Services Software User's Guide*.

## Disabling an Adapter Port to Suspend Traffic

**Question** How do I disable a configured adapter port to remove or test an adapter?

**Answer**

- 1** Access the command line interface (\* prompt).
- 2** Type **talk 5** and press **Enter** twice to reach the + prompt.
- 3** Enter the **configuration** command.
- 4** Make a note of the interface number of the adapter that you want to disable.
- 5** Enter **disable** *interface number*.

## Enabling an Adapter Port to Resume Traffic

**Question** How do I enable a configured adapter port (that was disabled using the **talk 5 disable** command in “Disabling an Adapter Port to Suspend Traffic”) to resume traffic?

**Answer**

- 1** Access the command line interface (\* prompt).
- 2** Type **talk 5** and press **Enter** twice to reach the + prompt.
- 3** Enter the **configuration** command.
- 4** Make a note of the interface number of the adapter you wish to enable.
- 5** Enter **test** *interface number*.

**Note:** If you use the **test** command to enable an interface that has been configured (in **talk 6**) as disabled, the next time that you reboot the 2216 the interface will be disabled again.

Therefore, you should also use the **talk 6 enable interface** command to ensure that the interface is enabled the next time a reboot does occur.

For details of this procedure, refer to the *Multiprotocol Access Services Software User's Guide*.

## Removing and Deleting an Adapter

**Question** How do I remove and delete an adapter from the configuration?

**Answer**

- 1** Access the command line interface (\* prompt).
- 2** Type **talk 6** and press **Enter** twice to reach the Config> prompt.
- 3** Enter **list device**.
- 4** On a sheet of paper, write down the interface number of the adapter you wish to delete.  
**Note:** If you are removing a multi-port adapter, then you need to record the interface number of all interfaces configured for that adapter.
- 5** Enter **delete interface** *interface number*.
- 6** At the Are you sure? prompt, enter **y**.
- 7** Enter **write** to save your changes.
- 8** Reboot the IBM 2216 to make the configuration changes active.

For details of this procedure, refer to the *Multiprotocol Access Services Software User's Guide*.

## Running Diagnostics

**Question** How are diagnostics run on a particular adapter?

**Answer** Refer to the *IBM 2216 Maintenance Guide*.

## Up-to-Date IBM 2216 Information

**Question** How can I find out the most current information about the IBM 2216?

**Answer** Point your web browser to <http://www.networking.ibm.com/216/216prod.html>

## Disabling Interfaces that have WAN Reroute Enabled

**Question** How do I ensure that WAN Reroute does not try to automatically enable an alternate interface that is on an adapter about to be removed?

### Answer

- 1 Access the command line interface (the \* prompt).
- 2 Type **talk 5**, and press **Enter** twice to reach the + (monitoring) prompt.
- 3 Type **feature wrs** to get to the WRS> prompt.
- 4 At the WRS> prompt, type **list alternate-circuit**.
- 5 If any of the alternate circuits are interfaces on the adapter that is about to be removed:  
Disable WAN Reroute/WAN Restoral altogether. Type **disable wrs**.  
*or*  
Disable WAN Reroute on an individual interface basis. Type **disable alternate-circuit**.
- 6 After WAN Reroute is disabled, go back to the + prompt by typing **exit**.
- 7 Type **disable slot** or the **disable interface#** for each interface on the adapter.

## Enable WAN Reroute after you have Disabled it

**Question** How do I enable WAN Reroute to automatically enable an alternate interface that is on an adapter that has be replaced?

### Answer

- 1 Access the command line interface (the \* prompt).
- 2 Type **talk 5** and press **Enter** twice to reach the + (monitoring) prompt.
- 3 Type **feature wrs** to get to the WRS> prompt.
- 4 If you disabled WAN Restoral/WAN Reroute altogether, type **enable wrs** to re-enable it.  
If you had just disabled an individual alternate-circuit, type **enable alternate-circuit** to re-enable the WAN Reroute's use of that alternate circuit.
- 5 After WAN Reroute is disabled, go back to the + prompt by typing **exit**.
- 6 Type **enable slot** to start a self-test for each interface on the adapter *or* type **test interface#** for each interface that you want to bring up.  
If you start a self-test for an alternate interface and the self-test is successful, the alternate interface will remain up even though it may not be needed to back-up a primary interface. If this happens, you can issue the talk 5 **disable interface#** command to put the alternate interface back into the standby (disabled) state.



---

## Appendix D. Factory Plugging Defaults

Units assembled at the factory follow the plugging rules that are described in this appendix.

---

### Assumptions

- No more than six of any combination of Token-Ring (FC 2280) and Ethernet (FC 2281) adapters will be installed.
- If a combination of **six** 2280 and 2281 adapters is to be installed, no other adapters will be installed.
- If a combination of **five** 2280 and 2281 adapters is to be installed, then two additional adapters can also be installed.
- A maximum of **four** ISDN adapters (2283 or 2292) can be installed.
- A maximum of **two** ATM adapters (2284 and 2293) can be installed.

---

### Plugging Sequences

Table D-1 illustrates how the slots are numbered: two rows of four slots, numbered 1 through 8:

Slot 1	Slot 2	Slot 3	Slot 4
Slot 5	Slot 6	Slot 7	Slot 8

These tables show the default sequence of installation for the various adapters.

FC 2280 and FC 2281 are installed left to right, beginning with slot 1. A maximum of six can be installed in any single IBM 2216.

1	3	5	
2	4	6	

Other adapters are installed right-to-left in the first-available slot beginning with slot 8 on the bottom and far right.

8	6	4	3
7	5	2	1



---

## Appendix E. Parts Listing

This parts listing contains reference drawings and a corresponding index for all field-replaceable parts. The index provides the part number, the quantity required (units), and a description of the part.

Listed below is additional information about the parts assembly index.

**SIMILAR ASSEMBLIES:** If two assemblies contain a majority of identical parts, they are broken down on the same list. Common parts are shown by one index number. Parts specific to one or the other of the assemblies are listed separately and identified by description.

**AR:** (As Required) in the Units column indicates that the quantity is not the same for all machines.

**NP:** (Non-Procurable) in the Units column indicates that the part is non-procurable and that the individual parts or the next higher assembly should be ordered.

**NR:** (Not Recommended) in the Units column indicates that the part is procurable but not recommended for field replacement, and that the next higher assembly should be ordered.

**R:** (Restricted) in the Units column indicates that the part has a restricted availability.

**INDENTURE:** The indenture is marked by a series of dots located before the parts description. The indenture indicates the relationship of a part to the next higher assembly. For example:

<b>Indenture</b>	<b>Relationship of Parts</b>
(No dot)	MAIN ASSEMBLY
(One dot)	• Detail parts of a main assembly
(One dot)	• Subassembly of the main assembly
(Two dot)	• • Detail part of a one-dot subassembly
(Two dot)	• • Subassembly of a one-dot subassembly
(Three dots)	• • • Detail part of a two-dot subassembly

# Assembly 1: Final Assembly, Routing Subsystem Console Commands - Model 400

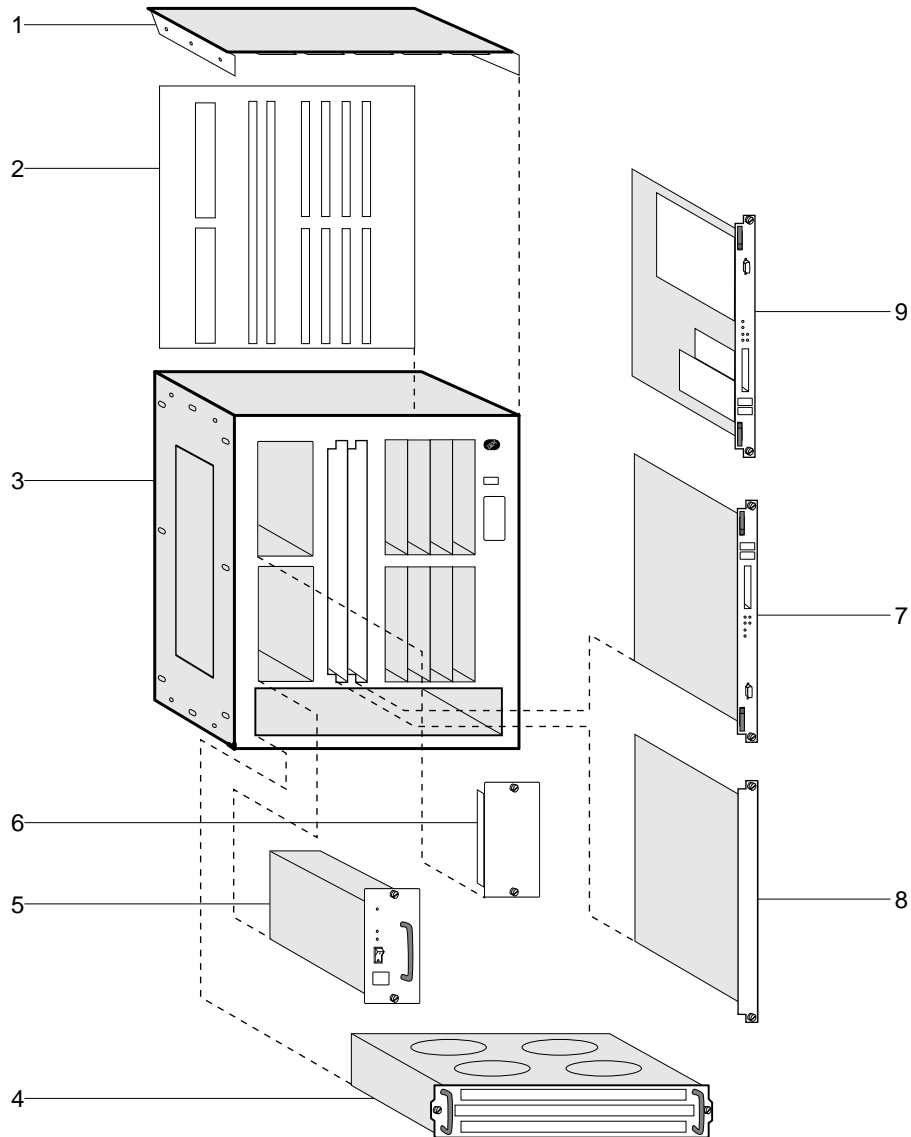

Asm- Index	Part Number	Units	Description
1-		NP	Final Assembly
-1	13H4931	1	• Cover, Top
-2	13H4945	1	• Backplane
-3	72H5099	1	• Enclosure
-4	72H5096	1	• Fan Tray
-5	25H4238	1	• Power Supply
-6	41H7701	1	• Power Supply Filler Plate
-7	38H7794	1	• System Card
-8	72H5101	1	• Filler Plate
-9	85H7917	1	• Hard Drive
-25	4H8169	1	• Wrap Plug Service Kit (Not Illus.)
-	41H6908	1	• LIC 280 (Not Illustrated)
-	41H6907	1	• LIC 281 (Not Illustrated)
-	85H4879	1	• LIC 282 (Not Illustrated)
-	85H4881	1	• LIC 283 (Not Illustrated)
-	85H5526	1	• LIC 284 (Not Illustrated)
-	85H4873	1	• LIC 290 (Not Illustrated)
-	85H4875	1	• LIC 291 (Not Illustrated)
-	85H4883	1	• LIC 292 (Not Illustrated)
-	85H6832	1	• LIC 293 (Not Illustrated)

## 2216-400 Feature Codes

NAME	FRU P/N	FEATURE CODE	DESCRIPTION
Sys Card -	85H7916	-- FC 2851	-- System Card
Hardfile -	39H2221	-- none	-- IDE 1.08G Hardfile
LIC280 ---	85H5543	-- FC 2280	-- 2 Port Token Ring
LIC281 ---	85H5542	-- FC 2281	-- 2 Port Ethernet
LIC282 ---	85H4872	-- FC 2282	-- 8 Port RS-232
LIC283 ---	85H4882	-- FC 2283	-- 1 Port ISDN Pri (T1)
LIC284 ---	85H4894	-- FC 2284	-- 1 Port 155Mbps (MMF ATM)
LIC287 ---	85H4878	-- FC 2287	-- 1 Port ESCON Channel
LIC290 ---	85H4874	-- FC 2290	-- 6 Port V.35/V.36)
LIC291 ---	85H4876	-- FC 2291	-- 8 Port X.21
LIC292 ---	85H4884	-- FC 2292	-- 1 Port ISDN Pri (E1)
LIC293 ---	85H6834	-- FC 22xx	-- 1 Port 155Mbps (SMF ATM)
Fans ---	85H6840	-- none	-- FAN Assembly
Power ---	85H7853	-- FC 2871	-- Power Supply
Backplane-	85H7860	-- none	-- 2216-400 Back Plane
Srv Kit --	85H7923	-- FC 2505	-- 2216-400 Wrap Plugs
Modem -	85H3549	-- FC 2900	-- US/Canada PCMCIA MODEM
Modem -	85H3550	-- FC 2901	-- Austria PCMCIA MODEM
Modem -	85H3551	-- FC 2902	-- Australia PCMCIA MODEM
Modem -	85H3552	-- FC 2903	-- Belgium PCMCIA MODEM
Modem -	85H3553	-- FC 2904	-- Denmark PCMCIA MODEM
Modem -	85H3554	-- FC 2905	-- Finland PCMCIA MODEM
Modem -	85H3555	-- FC 2906	-- France PCMCIA MODEM
Modem -	85H3556	-- FC 2907	-- Germany PCMCIA MODEM
Modem -	85H3557	-- FC 2908	-- Hong Kong PCMCIA MODEM
Modem -	85H3558	-- FC 2909	-- Ireland PCMCIA MODEM
Modem -	85H3559	-- FC 2910	-- Italy PCMCIA MODEM
Modem -	85H3560	-- FC 2911	-- Japan PCMCIA MODEM
Modem -	85H3561	-- FC 2912	-- Korea PCMCIA MODEM
Modem -	85H3562	-- FC 2913	-- Luxemburg PCMCIA MODEM
Modem -	85H3563	-- FC 2914	-- Netherland PCMCIA MODEM
Modem -	85H3564	-- FC 2915	-- New Zealand PCMCIA MODEM
Modem -	85H3565	-- FC 2916	-- Norway PCMCIA MODEM
Modem -	85H3569	-- FC 2921	-- Sweden PCMCIA MODEM
Modem -	85H3570	-- FC 2922	-- Switzerland PCMCIA MODEM
Modem -	85H3571	-- FC 2925	-- UK PCMCIA MODEM
Modem -	85H6839	-- FC 2927	-- Israel PCMCIA MODEM
Cable -	85H3589	-- none	-- Modem Cable

Figure E-1.

## 2216 Feature Card Cables

PN	RELEASE 1 2216-400 CABLES	FEATURE
85H5539	MFI BM FOR LIC 282 EIA-232/V.24 FANOUT CABLE	FC 2701
85H6822	MES BM FOR LIC 282 EIA-232/V.24 FANOUT CABLE	
85H5531	MFI BM FOR LIC 290 V.35 FANOUT CABLE	FC 2702
85H5548	MES BM FOR LIC 290 V.35 FANOUT CABLE	
85H5537	MFI BM FOR LIC 290 V.36 FANOUT CABLE	FC 2703
85H6820	MES BM FOR LIC 290 V.36 FANOUT CABLE	
85H5535	MFI BM FOR LIC 291 X.21 FANOUT CABLE	FC 2704
85H6818	MES BM FOR LIC 291 X.21 FANOUT CABLE	
85H5532	MFI BM FOR LIC 282 EIA-232/V.24 SERIAL INTERFACE	FC 2705
85H5549	MES BM FOR LIC 282 EIA-232/V.24 SERIAL INTERFACE	
85H5528	MFI BM FOR LIC 282 EIA-232/V.24 DIRECT ATTACH	FC 2706
85H5545	MES BM FOR LIC 282 EIA-232/V.24 DIRECT ATTACH	
85H5533	MFI BM FOR LIC 290 V.35 SERIAL INTERFACE	FC 2707
85H6816	MES BM FOR LIC 290 V.35 SERIAL INTERFACE	
85H5536	MFI BM FOR LIC 290 V.35 DIRECT ATTACH	FC 2708
85H6819	MES BM FOR LIC 290 V.35 DIRECT ATTACH	
85H5538	MFI BM FOR LIC 290 V.36 SERIAL INTERFACE	FC 2709
85H6821	MES BM FOR LIC 290 V.36 SERIAL INTERFACE	
85H5540	MFI BM FOR LIC 290 V.36 DIRECT ATTACH	FC 2710
85H6823	MES BM FOR LIC 290 V.36 SERIAL INTERFACE	
85H5530	MFI BM FOR LIC 291 X.21 SERIAL INTERFACE	FC 2711
85H5547	MES BM FOR LIC 291 X.21 SERIAL INTERFACE	
85H5534	MFI BM FOR LIC 291 X.21 DIRECT ATTACH	FC 2712
85H6817	MES BM FOR LIC 291 X.21 DIRECT ATTACH	
85H6828	MFI BM FOR MULTIPURPOSE RJ-45 STP CABLE	FC 2713
85H6829	MES BM FOR MULTIPURPOSE RJ-45 STP CABLE	
85H6824	MFI BM FOR LIC 283 ISDN PRI CABLE (T1)	FC 2714
85H6825	MES BM FOR LIC 283 ISDN PRI CABLE (T1)	
85H6826	MFI BM FOR LIC 292 ISDN PRI CABLE (E1)	FC 2715
85H6827	MES BM FOR LIC 292 ISDN PRI CABLE (E1)	
85H5527	MFI BM FOR LIC 283 ISDN PRI CABLE (J1)	FC 2716
85H5529	MES BM FOR LIC 283 ISDN PRI CABLE (J1)	
85H7858	MFI BM V.35 SERIAL CABLE - FRANCE	FC 2799

Figure E-2.





---

## List of Abbreviations

<b>ac</b>	alternating current	<b>Gbps</b>	giga bits per second (1 000 000 000 bits per second)
<b>ANSI</b>	American National Standards Institute	<b>GUI</b>	graphical user interface
<b>ATM</b>	asynchronous transfer mode	<b>HDLC</b>	high-level data link control
<b>Bc</b>	committed burst size	<b>HPFS</b>	high performance file system
<b>Be</b>	excess burst size	<b>HS</b>	high-speed
<b>bps</b>	bits per second	<b>HSA</b>	high-speed adapter (module)
<b>BSC</b>	binary synchronous communication	<b>HSDS</b>	High Speed Digital Services
<b>CAS</b>	channel associated signaling	<b>HSSI</b>	high-speed serial interface
<b>CCS</b>	(1) common channel signaling (2) change control server	<b>IDNX</b>	Integrated Digital Network Exchange
<b>CDB</b>	configuration database	<b>IP</b>	Internet Protocol
<b>CES</b>	circuit emulation service	<b>ISDN</b>	integrated-services digital network
<b>CIR</b>	committed information rate	<b>ISM</b>	IBM Solution Manager
<b>CMIP</b>	Common Management Information Protocol	<b>ISMD</b>	IBM Software Manufacturing and Delivery
<b>CMIS</b>	Common Management Information Services	<b>ITU-T</b>	International Telecommunication Union - Telecommunication (replaces CCITT)
<b>CMOT</b>	CMIP over TCP/IP	<b>Kbps</b>	kilo bits per second (1000 bits per second)
<b>CNM</b>	communication network management	<b>LAN</b>	local area network
<b>CP</b>	control point	<b>LAPD</b>	link access procedure for D-channel
<b>CRC</b>	cyclic redundancy check	<b>LED</b>	light-emitting diode
<b>dc</b>	direct current	<b>LIC</b>	line interface coupler
<b>DCD</b>	dc distribution (module)	<b>LMI</b>	local management interface
<b>DCE</b>	data circuit-terminating equipment	<b>LS</b>	low-speed
<b>DC48</b>	dc power input type -48V	<b>LSA</b>	low-speed adapter (module)
<b>DLCI</b>	data link connection identifier	<b>MB</b>	megabyte (1 048 576 bytes)
<b>DTE</b>	data terminal equipment	<b>Mbps</b>	mega bits per second (1 000 000 bits per second)
<b>DTMF</b>	dual-tone modulation frequency	<b>ms</b>	millisecond (1/1000 second)
<b>DTR</b>	data terminal ready	<b>NIC</b>	Network Information Center
<b>E&amp;M</b>	earth & mark	<b>NMS</b>	network management station
<b>ESF</b>	extended status flags	<b>NNI</b>	network-to-network interface
<b>FANB</b>	fan box	<b>NRZ-1</b>	non-return-to-zero change-on-ones recording
<b>FAT</b>	file allocation table	<b>NSAP</b>	network service address point
<b>FEP</b>	front-end processor	<b>NSC</b>	Network Support Center
<b>FR</b>	frame relay	<b>NVDM</b>	NetView Distribution Manager/6000
<b>FRFH</b>	frame relay frame handler	<b>OC</b>	optical carrier
<b>FRTE</b>	frame relay terminal equipment	<b>OSI</b>	open systems interconnection
<b>FRU</b>	field replaceable unit		
<b>FTP</b>	File Transfer Protocol		

<b>PBX</b>	private branch exchange	<b>SDH</b>	synchronous digital hierarchy
<b>PCM</b>	pulse code modulation	<b>SDLC</b>	synchronous data link control
<b>PDH</b>	plesiochronous digital hierarchy	<b>SDT</b>	structured data transfer
<b>PM</b>	Presentation Manager*	<b>SLA</b>	serial link architecture
<b>PNP</b>	private numbering plan	<b>SLIP</b>	Serial Line Internet Protocol
<b>PPP</b>	point-to-point protocol	<b>SNA</b>	Systems Network Architecture
<b>PRS</b>	primary reference source	<b>SNMP</b>	simple network management protocol
<b>PSN</b>	public switched network	<b>SONET</b>	synchronous optical network
<b>PSTN</b>	public switched telephone network	<b>SRC</b>	system reference code
<b>PVC</b>	permanent virtual circuit	<b>STM-1</b>	synchronous transport module-1
<b>PTM</b>	packet transfer mode	<b>SW</b>	switch (module)
<b>QoS</b>	quality of service	<b>SWRD</b>	switch redrive (module)
<b>RETAIN</b>	Remote Technical Assistance Information Network	<b>TCP/IP</b>	Transmission Control Protocol, Internet Protocol
<b>RSC</b>	Remote Support Center	<b>TDM</b>	time division multiplexing
<b>RSF</b>	Remote Support Facility	<b>UNI</b>	user network interface (protocol)
<b>RT</b>	real time	<b>VPD</b>	vital product data
<b>s</b>	second	<b>WAN</b>	wide area network

---

# Glossary

This glossary includes terms and definitions from:

- The *IBM Dictionary of Computing* (New York; McGraw-Hill, Inc., 1994).
- The *American National Standard Dictionary for Information Systems*, ANSI X3.172-1990, copyright 1990 by the American National Standards Institute (ANSI). Copies can be purchased from the American National Standards Institute, 1430 Broadway, New York, New York 10018. Definitions are identified by the symbol (A) after the definition.

**asynchronous transfer mode (ATM).** A connection-oriented access service to transfer data, voice, and video on broadband networks at very high speeds. These traffic types are mixed together over the available link bandwidth rather than being isolated into dedicated chunks of bandwidth.

The current ATM is for speeds of 155 Mbps and 622 Mbps but it will be capable of speeds in range of gigabits per second.

ATM divides all traffic into fixed-length cells, each containing 48 bytes of user data and five bytes of overhead, and manages the flow of these cells through the network.

**broadband.** A large frequency band allowing different kinds of transmissions, such as coded voice, video, and data, at the same time.

**change control server (CCS).** A station that runs the NetView Distribution Manager/6000 to store the Nways Switch programs and control the code changes.

A change control server is connected to its management access Nways Switch via an Ethernet LAN.

**channelization.** The process of breaking the bandwidth on a communication line into a number of channels, possibly of different size. Also called *time division multiplexing* (TDM).

**circuit emulation service (CES).** An access service used to carry information between two devices with a constant rate input and output. The incoming data can be voice, video, fax, multimedia, or synchronous data in real-time.

**code file.** A named set of records stored as a unit. An Nways Switch code file may include data or internal code. It is stored in a change control server.

**configuration database (CDB).** A database that stores the configuration parameters of one or several

Nways Switches. It is prepared and updated using the Nways Switch Configuration Tool (NCT).

**control point (CP).** The logical resource of the Nways Switch that provides the network control functions of the NBBS architecture. It may have a backup.

**dummy module.** A cover inserted in the place of a module to ensure a correct air cooling inside an Nways Switch logic subrack. During normal operation, the dummy modules must not be removed.

**equivalent capacity.** In the NBBS architecture, the minimum amount of bandwidth needed by a connection to ensure that the packet loss ratio is below a specified threshold.

**fax.** Hardcopy received from a facsimile machine. Synonymous with *telecopy*.

**frame relay (FR).** (1) An interface standard describing the boundary between user equipment and a fast-packet network. In frame relay systems, flawed frames are discarded, recovery is done end-to-end rather than hop-by-hop. (2) A technique derived from the D-channel standard of the integrated services digital network (ISDN).

**front-end processor (FEP).** A processor, such as the IBM 3745 or 3174, that relieves a main frame from the communication control tasks.

**high-level data link control (HDLC).** An access service used over data networks. It uses a non-real-time connection.

The Nways Switch supports any HDLC-like data link control, for example:

- Synchronous data link control (SDLC) used with SNA, or
- Link access procedure for D-channel (LAP-D) used with ISDN.

**hot pluggable.** Refers to a hardware component that can be installed or removed without disturbing the operation of any other resource that is not connected to, or dependant on, this component.

**hub (intelligent).** A wiring concentrator, such as the IBM 8260, that provides bridging and routing functions for LANs with different cables and protocols.

**Integrated Digital Network Exchange (IDNX).** A processor integrating voice, data, and image applications. It also manages the transmission resources, and connects to multiplexers and network

management support systems. It allows integration of equipment from different vendors.

**Internet.** A worldwide network connecting users through autonomous networks in industry, education, government, and research. The Internet network uses Internet Protocol (IP). The major Internet services include electronic mail, FTP, telnet, World Wide Web, and electronic bulletin boards (Usenet). For network interconnection and routing, and Transmission Control Protocol (TCP) for end-to-end control. (A)

**jitter.** (1) Short-term non-cumulative variations of the significant instants of a digital signal from their ideal positions in time. (2) Undesirable variations of a transmitted digital signal. (3) Variations in the network delay.

**line.** In an NBBS network, a communication link which can be a trunk line or a port line.

**local area network (LAN).** A computer network located on a user's premises within a limited geographical area.

**management access.** An Nways Switch that connects a network management station, or a change control server, to an NBBS network.

**module.** In the Nways Switch, a packaged functional hardware unit containing logic cards, connectors, and lights. The modules are used to package adapters, line interface couplers, voice server extensions, and other components. All modules are *hot pluggable* in the logic subracks.

**network control.** The functions of the NBBS architecture that are performed by a control point of the Nways Switch to:

- Allocate and control the Nways Switch resources
- Provide the topology and directory services
- Select the routes
- Control congestion.

**network management station (NMS).** A station that runs NetView/AIX and the Nways Switch Manager. It manages the NBBS network topology, accounting, performance, configuration updates, and problem analysis.

A network management station is connected to its management access Nways Switch via an Ethernet LAN.

**Network Support Center (NSC).** A location from which IBM provides remote support to NBBS networks.

**Non-Return-to-Zero Changes-on-Ones Recording (NRZ-1).** A recording method in which the ones are represented by a change in the condition of

magnetization, and zeros are represented by the absence of change. Only the one signals are explicitly recorded. (Previously called *non-return-to-zero inverted*, NRZI, recording.)

**Nways Switch.** Synonymous with IBM 2216 *Nways BroadBand Switch*.

**network support station (network support station).** The processor used to locally operate and service the Nways Switch. It is used by the Nways Switch administrator or service personnel.

**Nways Switch configuration station.** A dedicated OS/2 station running a stand-alone version of the Nways Switch Configuration Tool (NCT). It is used to generate a network configuration database and should be installed as a remote console.

**packet loss ratio.** The probability that a packet will not reach its destination or not reach it within a specified time.

**permanent virtual circuit (PVC).** In X.25 and frame relay communications, a virtual circuit that has a logical channel permanently assigned to it at each data terminal equipment (DTE).

**port.** See *NBBS port*.

**port adapter.** A module, in models of the Nways Switch other than the 2216, running the code that provides the access services of the NBBS architecture to the port lines. In the 2216 the functions of the port adapter and the trunk adapter are combined in the Multiple Port/Trunk Adapter (MPTA).

**port line.** A communication line that connects an external user device to an Nways Switch and, thus, to the NBBS Network. It can have different access services and interfaces: circuit emulation service (CES), pulse code modulation (PCM), high-level data link control (HDLC), or frame relay (FR).

In the Nways Switch, each port line is associated with one (or several) NBBS port(s).

**potential connection.** In the NBBS architecture, a predefined connection between two devices external to the NBBS network. It is defined by configuration parameters stored at one of the end-point Nways Switches.

**private branch exchange (PBX).** A private telephone exchange for transmission of calls to and from the public telephone network.

**pulse code modulation (PCM).** A standard adopted for the digitalization of an analog voice signal. In PCM, the voice is sampled at a rate of eight kHz and each sample is coded in an 8-bit frame.

In an NBBS network, PCM is an alternative to circuit emulation services (CES) to carry voice and fax data.

**quality of service (QoS).** In the NBBS architecture, the quality of service guarantees the characteristics of a network connection. It concerns mainly end-to-end delay, jitter, and packet loss ratio.

**rack.** A metallic structure, with a standard 19-inch width, that houses Nways Switch hardware elements: logic subrack with modules, fan boxes, and power subrack with power units.

**real-time processing.** The manipulation of data that are required, or generated, by some process while the process is in operation. Usually the results are used to influence the process, and perhaps related processes, while it is occurring.

**remote console.** A station running OS/2, TCP/IP, and the remote Nways Switch Resource Control program. It can be connected to any network support station (network support station) to operate and service the Nways Switch remotely.

The connection may be through:

- A switched line using a modem
- The NBBS network, if the remote console is connected to its access Nways Switch through an Ethernet LAN.

Any network support station can be used as a remote console of another network support station.

**resource.** In the Nways Switch, a hardware element or a logical entity created by the Control Program. For example, the adapters, LICs, and lines are physical resources. The control points, NBBS trunks, NBBS ports, and connections are logical resources.

In an NBBS network, the resources must be configured before being operated.

**resource profile.** A record of the characteristics of an Nways Switch resource. It includes, for example, the part number or module name, the change level, and the name and phone number of the person to contact in case of problem.

**router.** A device, such as the IBM 6611, that connects LANs of different protocols to wide area networks.

**Serial Line Internet Protocol.** A protocol used over a point-to-point connection between two IP hosts over a serial line, for example, a serial cable or an RS232 connection into a modem, over a telephone line.

In an NBBS network, the SLIP is used over a connection between a network support station (network support station) and an IBM Network Support Center (NSC).

**spanning tree.** In the NBBS architecture, a logical tree touching every Nways Switch and providing a very fast and efficient way to multicast control information, such as the topology database updates.

**subrack.** A metallic structure installed in a Nways Switch rack to hold modules or power supply elements.

**switch module (SW).** An Nways Switch module that interconnects the adapters through an ATM cell switch. It may have a backup.

**switch redrive (SWRD).** A module of the 2216 Model 501 that drives the signals from the switch module in the Model 500 to the adapters of the Model 501. It may have a backup.

**time division multiplexing (TDM).** See *channelization*.

**Transmission Control Protocol/Internet Protocol (TCP/IP).** A set of communication protocols that support peer-to-peer connectivity functions for both local and wide area networks.

In an NBBS Network, the network support stations, adapters, management stations, and remote consoles are organized as an IP network for transmitting control messages.

**transport services.** The functions of the NBBS architecture that are performed by an MPTA of the Nways Switch to:

- Support the attachment of trunk lines to the Nways Switch
- Maximize the bandwidth utilization
- Guarantee the qualities of service
- Transfer packets between Nways Switches
- Manage logical queues and schedule transmission.

**trunk.** See *NBBS trunk*.

**trunk adapter.** A module, in model so the Nways Switch other than the 2216, running the code that provides the transport services of the NBBS architecture to the trunk lines. In the 2216 the functions of the port adapter and the trunk adapter are combined in the Multiple Port/Trunk Adapter (MPTA).

**trunk line.** A high-speed line connecting two Nways Switches. It can be a coaxial cable, fiber cable, or radio wave, for example, and may be leased from telecommunication companies.

In the Nways Switch, each trunk line is associated with one NBBS trunk.

**virtual connection.** In frame relay, the return path of a potential connection.

**wide area network (WAN).** A network that provides communication services to a large geographic area. It may use, or provide, public communication facilities.

**2216 Nways BroadBand Switch.** A fast packet switch enabling high-speed communications over an NBBS

Network. The 2216 Nways BroadBand Switch implements the functions defined by the Networking BroadBand Services architecture. Synonymous with *Nways Switch*.

---

# Index

## Numerics

- 2216 firmware
  - boot sequence 4-4
  - configuration management 4-3
  - help 4-2
  - mode of operation 4-1
  - testing a device 4-5
  - using 4-1
  - utilities, using 4-7
- 2216 FRU exchange 3-1
- 2216 problem determination 2-1
  - basic verification 2-1

## A

- accessing the IBM 2216 5-1
- addresses, IP 4-18
- attended mode 4-1

## B

- boot sequence 4-4

## C

- change supervisory password 4-12
- configuration management 4-3
- control panel functions 1-1
- copying remote files 4-17

## D

- device test 4-5
- diagnostics, operational 5-1

## E

- error log, displaying 4-14

## F

- firmware 4-1
  - help 4-2

## H

- help panels 4-2

## I

- IP addresses 4-18
- IPL, setting up remote 4-18

## M

- managing the configuration 4-3

## O

- operational diagnostics 5-1
  - command line interface 5-1

## P

- parts catalog E-1
- password, supervisory 4-8, 4-9
  - removing 4-12

## R

- remote files, copying 4-17

## S

- selecting a device to test 4-5
- selecting the boot sequence 4-4
- setting the power-on password 4-8
- start mode
  - disabling 4-11
  - enabling 4-10
- starting firmware 4-2
- supervisory password 4-8, 4-9
  - removing 4-12

## T

- testing a device 4-5

## U

- Unattended mode 4-1
- Unattended start mode
  - disabling 4-11
  - enabling 4-10
- updating system firmware 4-13
- using the utilities 4-7
- utilities, using 4-7

## V

- vital product data 4-15

## X

- Xmodem software selection 4-19





---

# Tell Us What You Think!

## 2216 Nways Multiaccess Connector Maintenance Guide

Publication No. SY27-0350-00

We hope you find this publication useful, readable, and technically accurate, but only you can tell us! Your comments and suggestions will help us improve our technical publications. Please take a few minutes to let us know what you think by completing this form. If you are in the U.S.A., you can mail this form postage free or fax it to us at 1-800-253-3520. Elsewhere, your local IBM branch office or representative will forward your comments or you may mail them directly to us.

Overall, how satisfied are you with the information in this book?	Satisfied	Dissatisfied
	<input type="checkbox"/>	<input type="checkbox"/>

How satisfied are you that the information in this book is:	Satisfied	Dissatisfied
Accurate	<input type="checkbox"/>	<input type="checkbox"/>
Complete	<input type="checkbox"/>	<input type="checkbox"/>
Easy to find	<input type="checkbox"/>	<input type="checkbox"/>
Easy to understand	<input type="checkbox"/>	<input type="checkbox"/>
Well organized	<input type="checkbox"/>	<input type="checkbox"/>
Applicable to your task	<input type="checkbox"/>	<input type="checkbox"/>

Specific comments or problems:

---

---

---

Please tell us how we can improve this book:

---

---

---

Thank you for your comments. If you would like a reply, provide the necessary information below.

\_\_\_\_\_  
Name

\_\_\_\_\_  
Address

\_\_\_\_\_  
Company or Organization

\_\_\_\_\_

\_\_\_\_\_  
Phone No.

\_\_\_\_\_

Tell Us What You Think!  
SY27-0350-00



Cut or Fold  
Along Line

Fold and Tape

Please do not staple

Fold and Tape



NO POSTAGE  
NECESSARY  
IF MAILED IN THE  
UNITED STATES

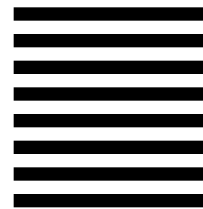

# BUSINESS REPLY MAIL

FIRST-CLASS MAIL PERMIT NO. 40 ARMONK, NEW YORK

POSTAGE WILL BE PAID BY ADDRESSEE

Design & Information Development  
Dept. CGF/Bldg. 656  
International Business Machines Corporation  
PO BOX 12195  
RESEARCH TRIANGLE PARK NC 27709-9990



Fold and Tape

Please do not staple

Fold and Tape

SY27-0350-00

Cut or Fold  
Along Line





Part Number: 38H7827

